

PURPOSE-BUILT
Hydraulic Cylinders & Component Parts



★ PURPOSE-BUILT ★

American



...it takes a **TEAM!**



Setting the standard with an emphasis on teamwork and company culture.

Purpose-Built American craftsmanship takes a team—one that is unified in working together in the pursuit of shared goals. At Aggressive Hydraulics, we proudly cultivate a strong culture to ensure that we always provide you with world-class results.

STATEMENT FROM AGGRESSIVE HYDRAULICS

Aggressive Hydraulics was founded by a team of experienced professionals within the Mobile Hydraulic Cylinder Industry. The charter of the company has always been to provide our customers with options and superior service before, during and after the sale. We make it as easy as possible to do business with us.

We have differentiated ourselves from others in the industry by combining sound engineering practices and decades of experience in providing cylinder solutions where others have tried and failed. Our proprietary and custom developed ERP system drives expedient quotes and efficiently synchronizes manufacturing process scheduling. This tool provides our customers with accurate lead times while maintaining on-time delivery.

Our manufacturing facility is Purpose-Built solely for manufacturing custom, application specific, mobile hydraulic cylinders. We have the unique combination of manual, semi-automated and fully automated equipment for manufacturing one piece to production quantities.

In addition to various batch size capability, our product capability includes both small and large bore cylinders, single- and double-acting telescoping cylinders, and extremely long cylinders.

We have confidence in standing behind our products and services due to our robust Quality Management System and our strong set of Values. Our Core Values have been guiding principles for conducting our business as it relates to our customers, our employees, our suppliers and our community. These principles have been key to our success. We strive to be the hydraulic cylinder supplier of choice as well as an employer of choice.

Paul Johnson

Founder/CEO
Aggressive Hydraulics

INDUSTRY AFFILIATIONS

We proudly support the following fluid power organizations:



Member: National Fluid Power Association

Founded in 1953, the National Fluid Power Association (NFPA) is the only trade Association focused exclusively on fluid power technology with members representing the entire fluid power supply chain.



Member: Equipment Service Association

The Equipment Service Association (ESA) is an association of companies successfully engaged in the sales and service of hydraulically, pneumatically or electrically operated tools, components, and equipment.



Member: International Fluid Power Society

The International Fluid Power Society strengthens and advances professional careers in the fluid power workforce through their work in education, training, and certification.

Aggressive Hydraulics is ISO 9001:2015 Certified



TABLE OF CONTENTS



Custom Hydraulic Cylinders

- 01** Introduction
- 03** Why Choose Welded?
- 05** Welded Design
- 07** Integrated Valve
- 09** Position Sensing (Smart)
- 11** Telescopic
- 13** Mill-Duty
- 15** High Pressure
- 17** Unique Solutions

Pre-Engineered Hydraulic Cylinders

- 19** Introduction
- 21** 100 Series
- 23** 200 Series
- 25** 300 Series
- 27** 400 Series
- 29** 600 Series
- 31** 700 Series
- 33** 800 Series
- 35** 900 Series

Component Parts

- 37** Introduction
- 38** Head Glands
- 45** Pistons
- 47** End Caps
- 49** Mounts
- 59** Ports
- 61** Valve Blocks
- 62** Fluid Line Elbow
- 63** Accessories

Facility Tour & Resources

- 67** Introduction
- 69** Website Tools
- 70** Technical Reference



CUSTOM HYDRAULIC CYLINDERS

Innovative Engineering Solutions

Our engineering team combines decades of experience with computer-aided technology. Allowing us to deliver the precise hydraulic cylinder solution to fit your requirements.



WHY CHOOSE WELDED?

Robust and reliable design with application specific customization

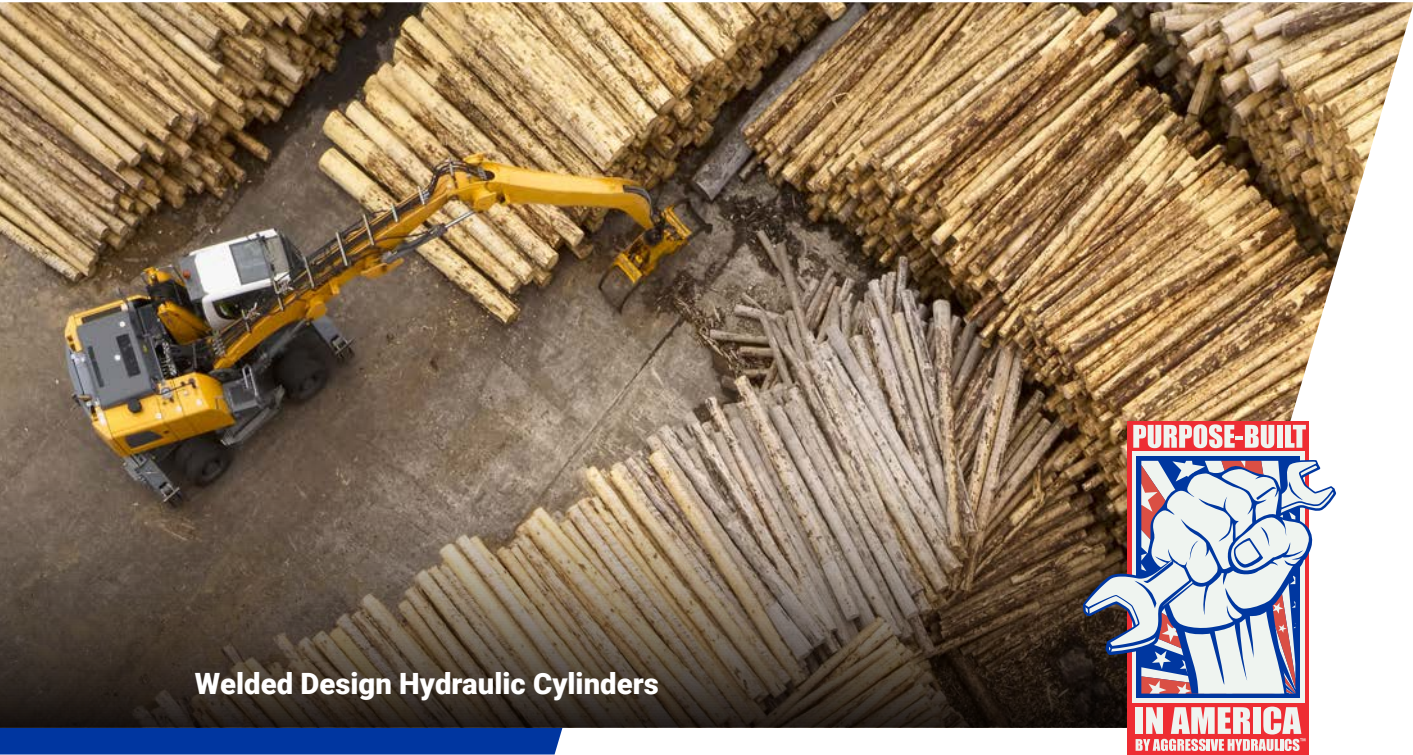

Welded Design Hydraulic Cylinders

In all types of industrial and mobile machinery, downtime is costly, especially related to hydraulic leaks. Welded construction cylinders from Aggressive Hydraulics are designed to significantly reduce the potential of these types of failures.

Key Advantages of Aggressive Hydraulics Welded Cylinders:

- Greater integrity in high pressure, high duty cycle, and high vibration applications
- Compact envelope dimensions with robust and aesthetic appearance
- Design flexibility not limited to predetermined catalog options
- Integral valve options with welded fluid lines eliminate threaded connections
- Flexible port sizes and locations
- Designed to be repairable

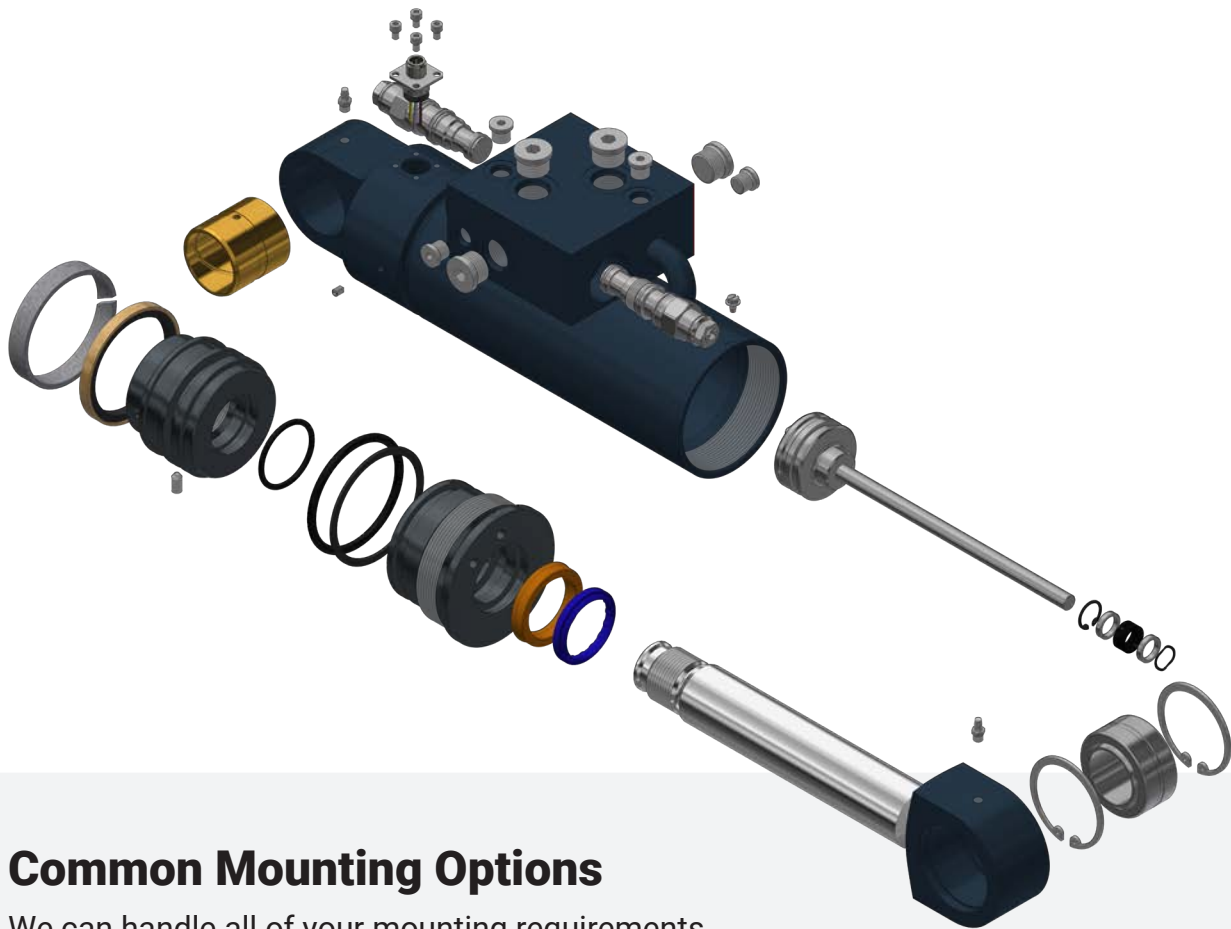

Common Mounting Options

We can handle all of your mounting requirements.
Contact us for any special mounting requests.

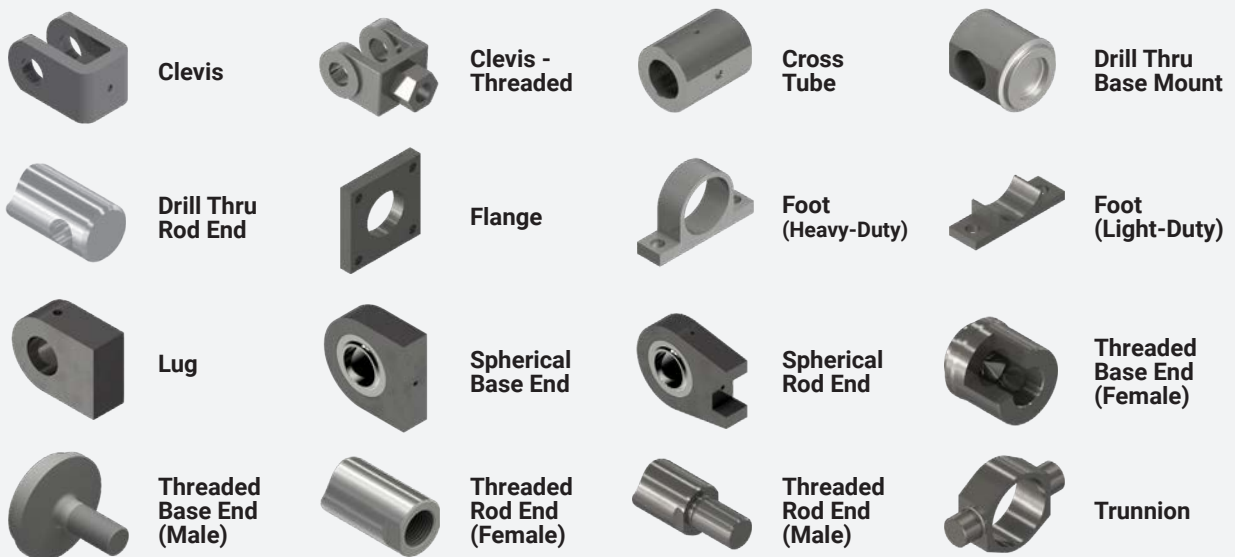

WELDED DESIGN

Custom Hydraulic Cylinders



Welded Design Hydraulic Cylinders: Medium-Duty

Robust, Flexible, and Reliable

Aggressive Hydraulics builds welded design hydraulic cylinders for total reliability. Our engineering team takes your requirements and designs a premium cylinder to exceed them.

Application experience and focus on quality of designs are why we have a history of building hydraulic cylinders that last.

Medium-Duty:

System pressures up to 2,500 psi

Heavy-Duty:

System pressures up to 5,000 psi



Features & Specifications

- Single- & double-acting configurations
- Common bore sizes from 1-1/2" to 20"
- Common stroke lengths up to 300"
- Standard carbon, alloy & stainless steel material options available based on application
- Standard paint options include vinyl acrylic primer & enamel, special paints available upon request
- Plating/treatment options available based on application
- Seals selected based on fluid, pressure & temperature



Welded Design Hydraulic Cylinders: Heavy-Duty

INTEGRATED VALVE

Custom Hydraulic Cylinders



Integrated Valve Hydraulic Cylinders

Safety, Performance, and Aesthetics

When your application requires counterbalance or pilot operated check valves, the ideal location is directly mounted to the cylinder because it continues to provide load holding protection even when a hose fails.

From basic single or dual counterbalance valves to complex integrated circuits, our team will design your cylinders with compact valve manifolds.

Direct Mounting Can Eliminate:

- Mounting brackets
- Hardware
- Fluid connectors
- Assembly time

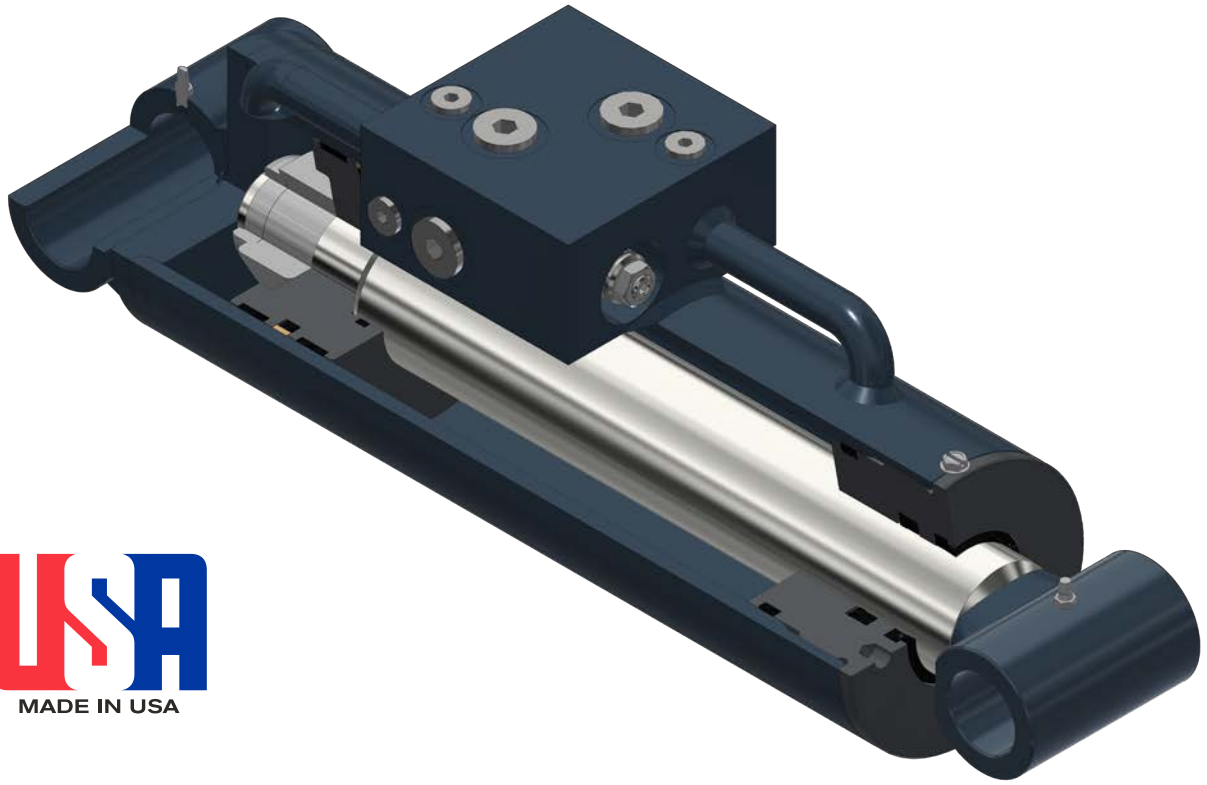

Features & Specifications

- Valve & porting location flexibility
- Sanitary plumbing improves aesthetics
- Welded fluid lines eliminate threaded connections
- Numerous safety benefits

Common Options

- Counterbalance valves
- Pilot operated check valves
- Solenoid valves
- Relief valves
- Velocity fuses
- Sequence valves
- Regenerative circuits



Integrated Valve Hydraulic Cylinders

POSITION SENSING (SMART)

Custom Hydraulic Cylinders



Position Sensing (Smart) Hydraulic Cylinders

Advanced Technology Integration

When your machine is ready for all the benefits and reliability of electronic position feedback, it is time to integrate a linear transducer in your hydraulic cylinders. We have a proven track record of designing and manufacturing smart cylinders for a wide variety of mobile and industrial applications.

Engineering Utilizes Combinations of:

- Computer-aided technology
- Smart cylinder design experience
- State-of-the-art manufacturing

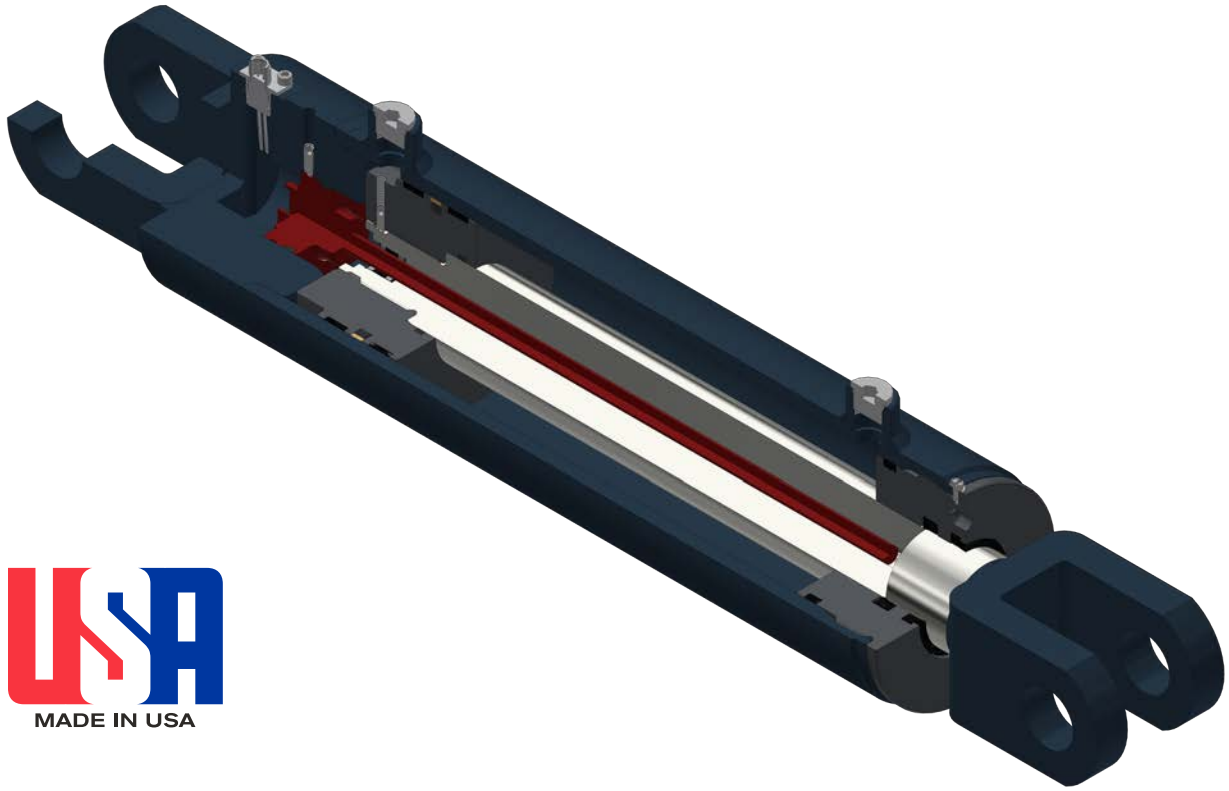

Features & Specifications

- Stroke lengths to 300"
- Hydraulic pressure to 5,000 psi
- Temperature -40°F to 221°F
- Typical connections:
 - Circular: M12, M16, military spec
 - Deutsch
 - Cable
- Typical output types:
 - Analog: 4-20mA, 0.5-4.5Vdc, 0-10Vdc
 - Digital: CAN, SSI, Ethernet
- Sensor Technology Types:
 - Magnetostrictive, Hall Effect, Resistive & Inductive
- Ingression protection:
 - IP67, IP68 & IP69K available



Position Sensing (Smart) Hydraulic Cylinders

TELESCOPIC

Custom Hydraulic Cylinders



Telescopic Hydraulic Cylinders

Application-Specific Designs

Telescopic hydraulic cylinders utilize multiple nested stages to achieve a long working stroke while maintaining a compact retracted envelope. Aggressive Hydraulics engineers application-specific designs to ensure that you get the proper cylinder for your application.

Telescopic Cylinder Types:

- Single-acting
- Double-acting
- Partially double-acting



Telescopic Cylinder Types: Special Options

• Single-Acting

Single-acting cylinders use hydraulic force to extend and gravity or some other external force to retract.

• Double-Acting

Double-acting cylinders use hydraulic force for both extension and retraction.

• Partially Double-Acting

Partially double-acting cylinders use hydraulic force to extend and for a portion of the retract stroke. Gravity or some other external force will complete the retract cycle.

- Double-acting configurations with both ports located on the main barrel

- Integrated valves

- Integrated linear sensors

- Skip-a-sleeve designs to increase the effective retract area on double-acting configurations

- 3,000 psi pressure rated designs

- Load holding piston seals

MILL-DUTY

Custom Hydraulic Cylinders



Mill Duty Hydraulic Cylinders

Engineered to Meet Extreme Demands

Aggressive Hydraulics Mill-Duty cylinders are robust to meet extreme demands, environments, and applications. Whether you require a cylinder for a new installation or a replacement for an existing application, our solutions will meet your needs.

Typical Mill-Duty Applications Include:

- Steel mills
- Foundries
- Mining
- Civil engineering



Features & Specifications

- Easily serviced
- Robust, heavy-duty designs
- Bolted head
- Bolted end cap
- High performance
- High safety standards
- Extended wear, long service life

Special Options

- Chrome plated bore
- Fixed or adjustable cushions
- Air bleeds
- Special materials & plating
- High temperature seal package
- Integrated valves
- Linear transducers
- Proximity switches
- Dual mounting configurations



Mill Duty Hydraulic Cylinders

HIGH PRESSURE

Custom Hydraulic Cylinders



High Pressure Hydraulic Cylinders

Performance and Field Safety

High pressure hydraulic cylinders require precise engineering designs and high strength materials. Meeting exacting tolerances ensures performance and field safety. Aggressive Hydraulics has the knowledge and experience required to deliver your high pressure hydraulic cylinders.

What You're Getting:

- Precision engineering
- High strength materials
- State-of-the-art manufacturing



Special Options

- Chrome plated bore
- Adjustable cushions
- Air bleeds
- Special materials & plating
- Integrated valves
- Linear transducers
- Proximity switches
- Pressure boosters
- Intensifier designs
- ASME, ABS, DNV, USCG & API specifications

Features & Specifications

- Specialized applications & pressures up to 10,000 psi
- Robust, heavy-duty designs
- High-yield strength carbon or alloy steel materials
- Single- & double-acting designs

UNIQUE SOLUTIONS

Providing innovative solutions beyond manufacturing cylinders



Unique Hydraulic Cylinder Application

Aggressive Hydraulics can do more than just manufacture world class hydraulic cylinders. We are an extension to our customer's design and engineering team.

Our strong engineering capabilities allow us to provide unique solutions to our customer's needs that go beyond just manufacturing a hydraulic cylinder.

Aggressive Hydraulics team of engineers and technical sales representatives are ready to help put your ideas in motion.



**Don't see what you're looking for?
Contact us today.**

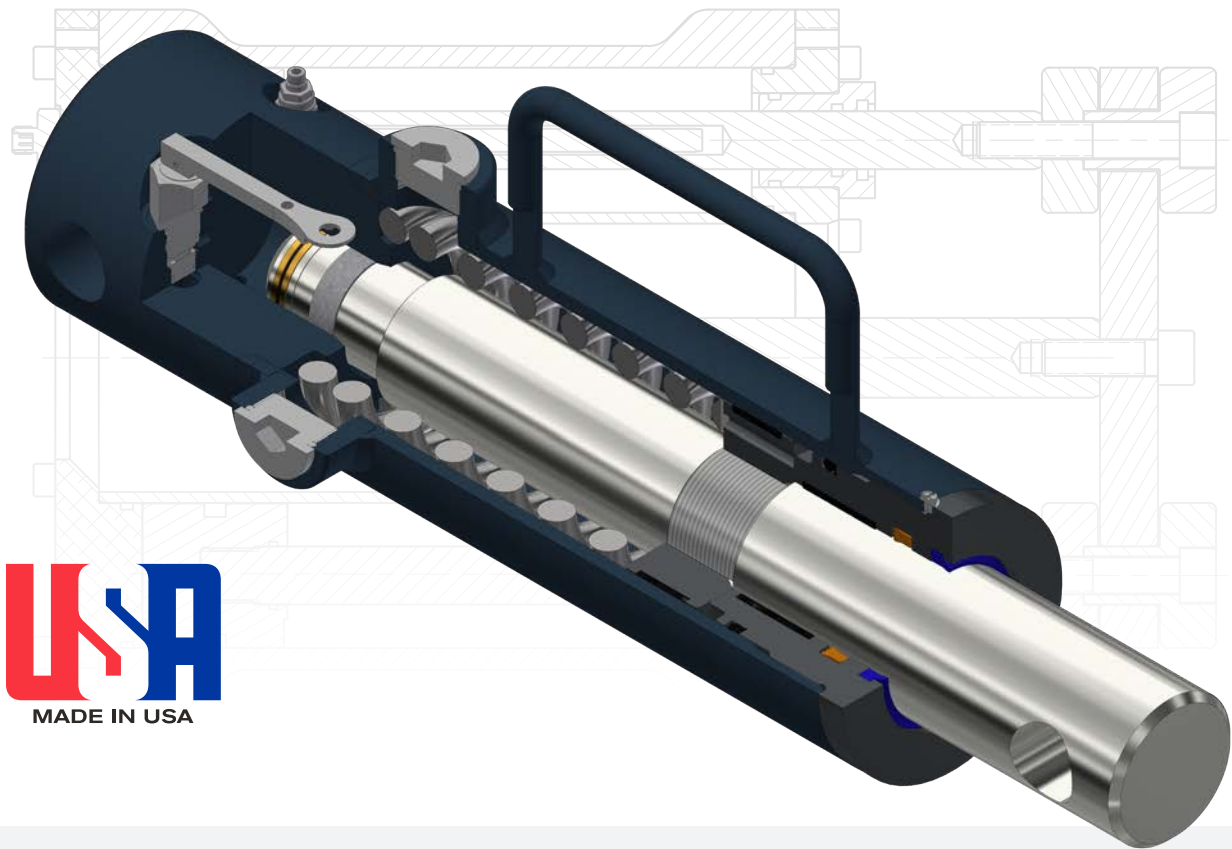



Unique Environments

- Sub-sea applications
- Harsh and extreme ambient operating conditions
- Caustic environments
- Food grade environments
- Pool water

Unique Applications

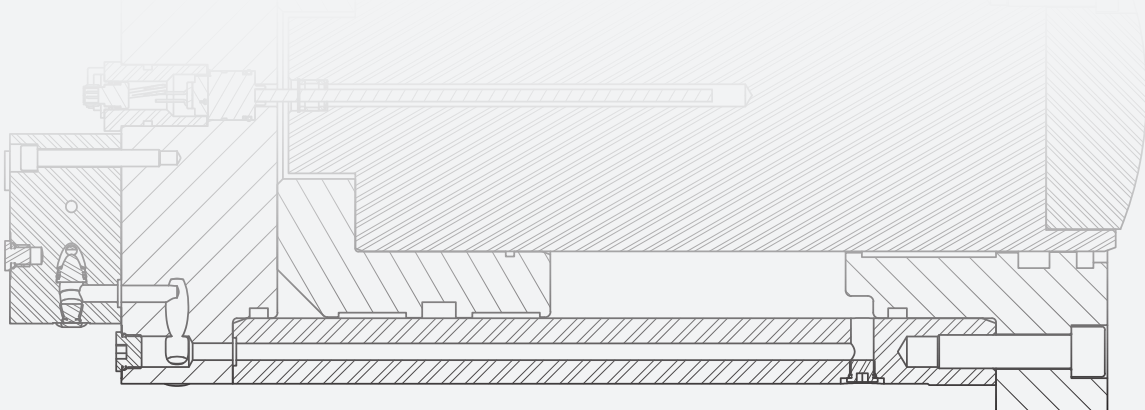
- Integrated accumulators
- Integrated electric power units
- Pressure intensifiers
- Auto reciprocating
- Stainless steel





PRE-ENGINEERED HYDRAULIC CYLINDERS

Easy Configuration, Quality You Expect

Pre-Engineered cylinders from Aggressive Hydraulics utilize the most common mounting configurations and bore to rod combinations. These are configurable from six basic styles and built-to-order based on your requirements and our standard cylinder component parts.



100 SERIES

MEDIUM-DUTY

PRE-ENGINEERED HYDRAULIC CYLINDERS

100 SERIES FEATURES:

- 2,500 psi medium-duty type
- Cold drawn (high impact) 75 ksi min. yield D.O.M. tubing
- Ground & polished, hard chrome plated rods (75 ksi min. yield)
- Welded style construction certified to A.W.S. B2.1
- Internally threaded head design with buttress threads
- Highest quality seal configurations compatible with petroleum base fluids
- Ductile iron head gland & piston
- Piston utilizes wear bearings
- Nylon inserted lock nut
- Black primer

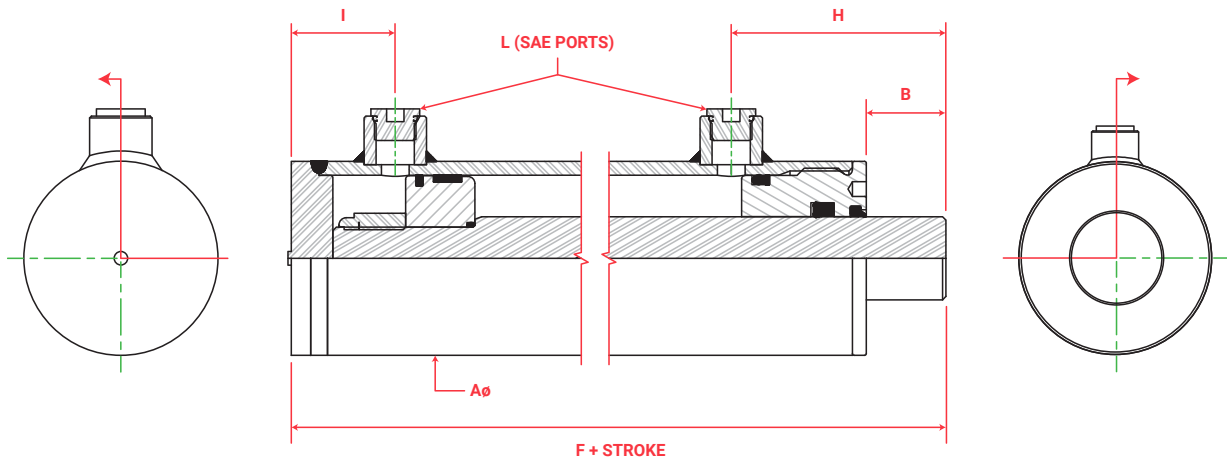

Pre-Engineered Cylinder Drawing Program

Instantly customize and print detailed drawings of our
100 Series Pre-Engineered Cylinders

100 SERIES CYLINDERS

Bore	Rod	A	B	F	H	I	L	Part #
1.50	.75	2.00	1.38	5.75	3.31	1.31	#4	104-**.**. **
	1.00	2.00	1.50	6.00	3.56	1.31	#4	106-**.**. **
2.00	1.00	2.50	1.38	6.25	3.62	1.38	#6	110-**.**. **
	1.12	2.50	1.50	6.25	3.62	1.38	#6	112-**.**. **
	1.25	2.50	1.50	6.50	3.88	1.38	#6	114-**.**. **
2.50	1.25	3.00	1.50	6.50	3.62	1.62	#6	118-**.**. **
	1.50	3.00	1.56	7.00	4.06	1.69	#6	120-**.**. **
3.00	1.25	3.50	1.56	7.00	4.00	1.75	#8	124-**.**. **
	1.50	3.50	1.44	7.00	3.88	1.88	#8	126-**.**. **
	1.75	3.50	1.44	7.00	3.88	1.88	#8	128-**.**. **
	2.00	3.50	1.44	7.25	4.12	1.88	#8	130-**.**. **
3.50	1.50	4.00	1.56	7.25	4.00	2.00	#8	134-**.**. **
	1.75	4.00	1.56	7.25	4.00	2.00	#8	136-**.**. **
	2.00	4.00	1.56	7.25	4.00	2.00	#8	138-**.**. **
4.00	1.50	4.50	1.44	7.25	3.88	2.12	#8	142-**.**. **
	1.75	4.50	1.50	7.50	3.94	2.31	#8	144-**.**. **
	2.00	4.50	1.50	7.50	3.94	2.31	#8	146-**.**. **
	2.50	4.50	1.50	7.75	4.19	2.31	#8	148-**.**. **
4.50	1.75	5.00	1.38	7.75	3.81	2.44	#8	152-**.**. **
	2.00	5.00	1.38	7.75	3.81	2.44	#8	154-**.**. **
	2.25	5.00	1.38	7.75	3.81	2.44	#8	156-**.**. **
5.00	2.00	5.62	1.50	8.25	3.94	2.81	#8	160-**.**. **
	2.50	5.62	1.50	8.50	4.19	2.81	#8	162-**.**. **
	3.00	5.62	1.50	8.50	4.19	2.81	#8	164-**.**. **

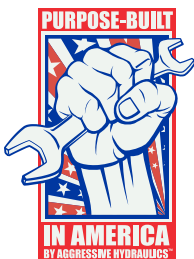

ORDERING INFORMATION

All Pre-Engineered Cylinders are manufactured in the U.S.A. and are backed by the Aggressive Hydraulics Cylinder Warranty.

- To complete part #, replace (**.**) with stroke required.
- Maximum allowable stroke length for a given model is dependent on the actual maximum operating pressure and compressive load. Buckling strength limit for a cylinder will be calculated at the time of initial order or upon customer request.
- Customized options available upon request.

© AGGRESSIVE HYDRAULICS • WE'RE SIMPLY A PHONE CALL AWAY

PHONE: 763-792-4000 • EMAIL: SALES@AGGRESSIVEHYDRAULICS.COM • WEB: WWW.AGGRESSIVEHYDRAULICS.COM

200 SERIES

MEDIUM-DUTY

PRE-ENGINEERED HYDRAULIC CYLINDERS

200 SERIES FEATURES:

- Cross tube style base and rod mounts
- 2,500 psi medium-duty type
- Cold drawn (high impact) 75 ksi min. yield D.O.M. tubing
- Ground & polished, hard chrome plated rods (75 ksi min. yield)
- Welded style construction certified to A.W.S. B2.1
- Internally threaded head design with buttress threads
- Highest quality seal configurations compatible with petroleum base fluids
- Ductile iron head gland & piston
- Piston utilizes wear bearings
- Nylon inserted lock nut
- Black primer

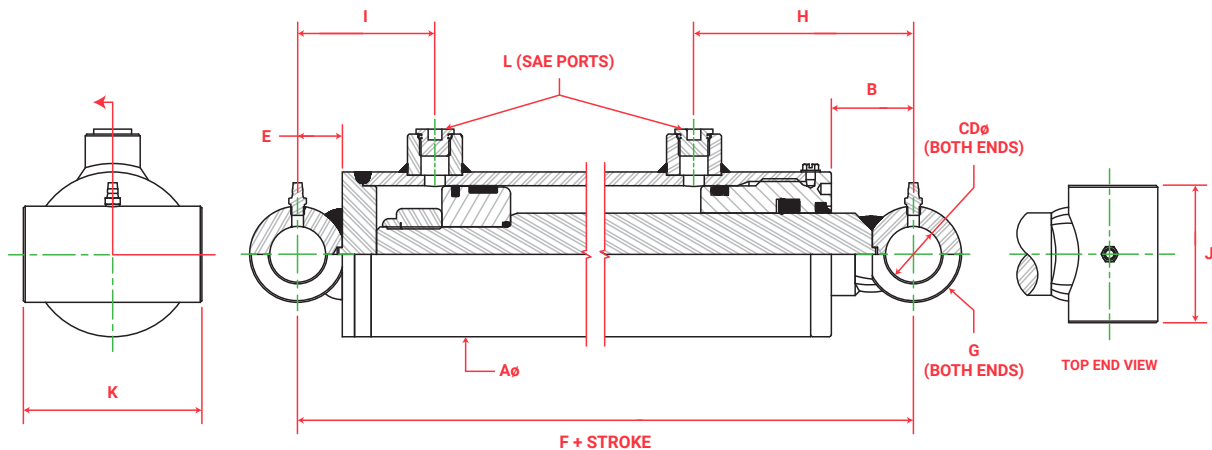

Pre-Engineered Cylinder Drawing Program

Instantly customize and print detailed drawings of our
200 Series Pre-Engineered Cylinders

200 SERIES CYLINDERS

Bore	Rod	A	B	CD	E	F	G	H	I	J	K	L	Part #
1.50	.75	2.00	1.31	.750	.56	6.25	.62	3.25	1.88	2.50	2.50	#4	204-**-**
	1.00	2.00	1.19	.750	.56	6.25	.62	3.25	1.88	2.50	2.50	#4	206-**-**
2.00	1.00	2.50	1.44	1.000	.69	7.00	.75	3.69	2.06	2.50	3.00	#6	210-**-**
	1.12	2.50	1.56	1.000	.69	7.00	.75	3.69	2.06	2.50	3.00	#6	212-**-**
	1.25	2.50	1.31	1.000	.69	7.00	.75	3.69	2.06	2.50	3.00	#6	214-**-**
2.50	1.25	3.00	1.69	1.000	.81	7.50	.88	3.81	2.44	2.50	3.25	#6	218-**-**
	1.50	3.00	1.50	1.000	.81	7.75	.88	4.00	2.50	2.50	3.25	#6	220-**-**
3.00	1.25	3.50	1.50	1.000	.81	7.75	.88	3.94	2.56	2.50	3.75	#8	224-**-**
	1.50	3.50	1.38	1.000	.81	7.75	.88	3.81	2.69	2.50	3.75	#8	226-**-**
	1.75	3.50	1.38	1.000	.81	7.75	.88	3.81	2.69	2.50	3.75	#8	228-**-**
	2.00	3.50	1.38	1.000	.81	8.00	.88	4.06	2.69	2.50	3.75	#8	230-**-**
3.50	1.50	4.00	1.44	1.250	.88	8.00	1.00	3.88	2.88	2.75	4.25	#8	234-**-**
	1.75	4.00	1.44	1.250	.88	8.00	1.00	3.88	2.88	2.75	4.25	#8	236-**-**
	2.00	4.00	1.44	1.250	.88	8.00	1.00	3.88	2.88	2.75	4.25	#8	238-**-**
4.00	1.50	4.50	1.56	1.250	.88	8.25	1.00	4.00	3.00	2.75	4.75	#8	242-**-**
	1.75	4.50	1.62	1.250	.88	8.50	1.00	4.06	3.19	2.75	4.75	#8	244-**-**
	2.00	4.50	1.62	1.250	.88	8.50	1.00	4.06	3.19	2.75	4.75	#8	246-**-**
	2.50	4.50	1.62	1.250	.88	8.75	1.00	4.31	3.19	2.75	4.75	#8	248-**-**
4.50	1.75	5.00	1.50	1.250	.88	8.75	1.00	3.94	3.31	2.75	5.25	#8	252-**-**
	2.00	5.00	1.50	1.250	.88	8.75	1.00	3.94	3.31	2.75	5.25	#8	254-**-**
	2.25	5.00	1.50	1.250	.88	8.75	1.00	3.94	3.31	2.75	5.25	#8	256-**-**
5.00	2.00	5.62	1.88	1.500	1.12	9.75	1.25	4.31	3.94	2.75	6.00	#8	260-**-**
	2.50	5.62	1.88	1.500	1.12	10.00	1.25	4.56	3.94	2.75	6.00	#8	262-**-**
	3.00	5.62	1.88	1.500	1.12	10.00	1.25	4.56	3.94	4.25	6.00	#8	264-**-**

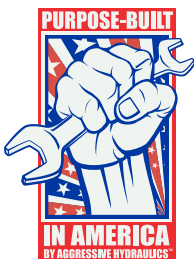

ORDERING INFORMATION

All Pre-Engineered Cylinders are manufactured in the U.S.A. and are backed by the Aggressive Hydraulics Cylinder Warranty.

- To complete part #, replace (**)** with stroke required.
- Maximum allowable stroke length for a given model is dependent on the actual maximum operating pressure and compressive load. Buckling strength limit for a cylinder will be calculated at the time of initial order or upon customer request.
- Customized options available upon request.

300 SERIES

MEDIUM-DUTY

PRE-ENGINEERED HYDRAULIC CYLINDERS

300 SERIES FEATURES:

- Clevis style base and rod mounts
- 2,500 psi medium-duty type
- Cold drawn (high impact) 75 ksi min. yield D.O.M. tubing
- Ground & polished, hard chrome plated rods (75 ksi min. yield)
- Welded style construction certified to A.W.S. B2.1
- Internally threaded head design with buttress threads
- Highest quality seal configurations compatible with petroleum base fluids
- Ductile iron head gland & piston
- Piston utilizes wear bearings
- Nylon inserted lock nut
- Black primer

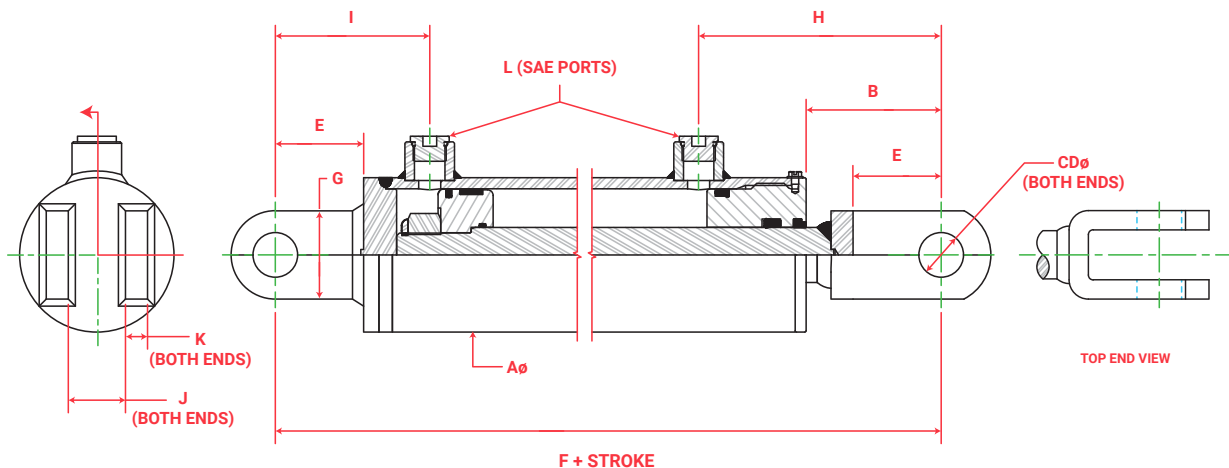

Pre-Engineered Cylinder Drawing Program

Instantly customize and print detailed drawings of our
300 Series Pre-Engineered Cylinders

300 SERIES CYLINDERS

Bore	Rod	A	B	CD	E	F	G	H	I	J	K	L	Part #
1.50	.75	2.00	3.00	.750	1.62	9.00	1.75	4.94	2.94	1.06	.38	#4	304-**.**. **
	1.00	2.00	2.88	.750	1.62	9.00	1.75	4.94	2.94	1.06	.38	#4	306-**.**. **
2.00	1.00	2.50	3.38	1.00	2.00	10.25	2.00	5.62	3.38	1.25	.50	#6	310-**.**. **
	1.12	2.50	3.50	1.00	2.00	10.25	2.00	5.62	3.38	1.25	.50	#6	312-**.**. **
	1.25	2.50	3.25	1.00	2.00	10.25	2.00	5.62	3.38	1.25	.50	#6	314-**.**. **
2.50	1.25	3.00	3.25	1.00	2.00	10.25	2.00	5.38	3.62	1.25	.50	#6	318-**.**. **
	1.50	3.00	3.06	1.00	2.00	10.25	2.00	5.56	3.44	1.25	.50	#6	320-**.**. **
3.00	1.25	3.50	3.06	1.00	2.00	10.25	2.00	5.50	3.50	1.25	.50	#8	324-**.**. **
	1.50	3.50	3.06	1.00	2.00	10.25	2.00	5.50	3.50	1.25	.50	#8	326-**.**. **
	1.75	3.50	3.06	1.00	2.00	10.25	2.00	5.50	3.50	1.25	.50	#8	328-**.**. **
	2.00	3.50	3.06	1.00	2.00	10.25	2.00	5.75	3.25	1.25	.50	#8	330-**.**. **
3.50	1.50	4.00	3.06	1.00	2.00	10.25	2.00	5.50	3.50	1.25	.50	#8	334-**.**. **
	1.75	4.00	3.06	1.00	2.00	10.25	2.00	5.50	3.50	1.25	.50	#8	336-**.**. **
	2.00	4.00	3.06	1.00	2.00	10.25	2.00	5.50	3.50	1.25	.50	#8	338-**.**. **
4.00	1.50	4.50	3.06	1.00	2.00	10.25	2.00	5.50	3.50	1.25	.50	#8	342-**.**. **
	1.75	4.50	3.06	1.00	2.00	10.25	2.00	5.50	3.50	1.25	.50	#8	344-**.**. **
	2.00	4.50	3.06	1.00	2.00	10.25	2.00	5.50	3.50	1.25	.50	#8	346-**.**. **
	2.50	4.50	3.25	1.00	2.00	11.25	2.00	5.94	4.06	1.25	.50	#8	348-**.**. **
4.50	1.75	5.00	3.38	1.25	2.00	11.75	2.50	5.81	4.44	1.62	.75	#8	352-**.**. **
	2.00	5.00	3.38	1.25	2.00	11.75	2.50	5.81	4.44	1.62	.75	#8	354-**.**. **
	2.25	5.00	3.38	1.25	2.00	11.75	2.50	5.81	4.44	1.62	.75	#8	356-**.**. **
5.00	2.00	5.62	4.25	1.50	2.50	13.50	3.00	6.69	5.31	2.12	1.00	#8	360-**.**. **
	2.50	5.62	4.25	1.50	2.50	13.75	3.00	6.94	5.31	2.12	1.00	#8	362-**.**. **
	3.00	5.62	4.25	1.50	2.50	13.75	3.00	6.94	5.31	2.12	1.00	#8	364-**.**. **

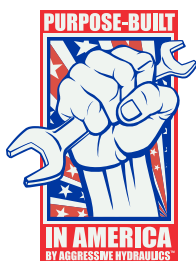

ORDERING INFORMATION

All Pre-Engineered Cylinders are manufactured in the U.S.A. and are backed by the Aggressive Hydraulics Cylinder Warranty.

- To complete part #, replace (**.**) with stroke required.
- Maximum allowable stroke length for a given model is dependent on the actual maximum operating pressure and compressive load. Buckling strength limit for a cylinder will be calculated at the time of initial order or upon customer request.
- Customized options available upon request.

400 SERIES

MEDIUM-DUTY

PRE-ENGINEERED HYDRAULIC CYLINDERS

400 SERIES FEATURES:

- Lug style base and rod mounts
- 2,500 psi medium-duty type
- Cold drawn (high impact) 75 ksi min. yield D.O.M. tubing
- Ground & polished, hard chrome plated rods (75 ksi min. yield)
- Welded style construction certified to A.W.S. B2.1
- Internally threaded head design with buttress threads
- Highest quality seal configurations compatible with petroleum base fluids
- Ductile iron head gland & piston
- Piston utilizes wear bearings
- Nylon inserted lock nut
- Black primer

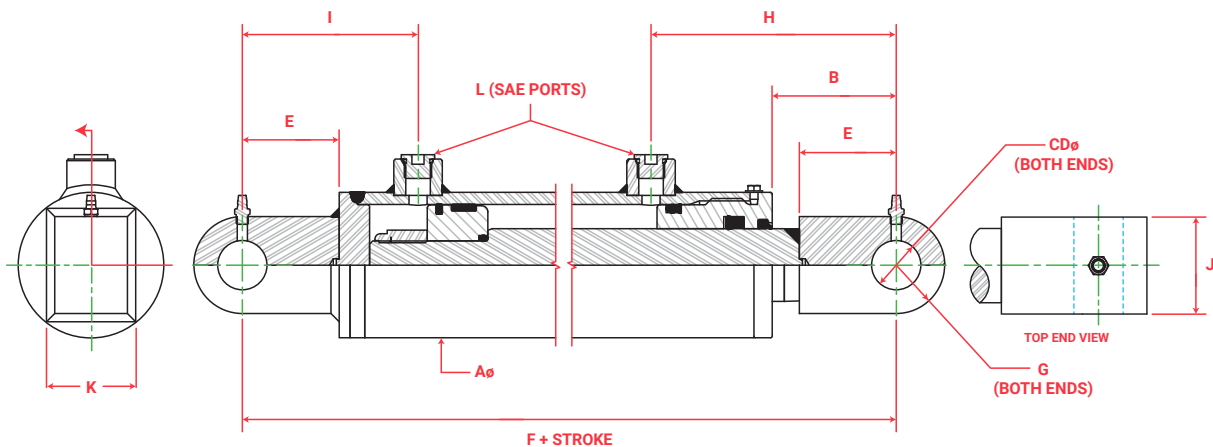

Pre-Engineered Cylinder Drawing Program

Instantly customize and print detailed drawings of our
400 Series Pre-Engineered Cylinders

400 SERIES CYLINDERS

Bore	Rod	A	B	CD	E	F	G	H	I	J	K	L	Part #
1.50	.75	2.00	2.12	.750	1.50	8.00	.75	4.06	2.81	.75	.75	#4	404-**-**
	1.00	2.00	2.00	.750	1.50	8.00	.75	4.06	2.81	1.00	1.00	#4	406-**-**
2.00	1.00	2.50	2.62	1.00	2.00	9.50	1.00	4.88	3.38	1.00	1.00	#6	410-**-**
	1.12	2.50	2.75	1.00	2.00	9.50	1.00	4.88	3.38	1.25	1.25	#6	412-**-**
	1.25	2.50	2.50	1.00	2.00	9.50	1.00	4.88	3.38	1.25	1.25	#6	414-**-**
2.50	1.25	3.00	2.75	1.00	2.00	9.75	1.00	4.88	3.62	1.25	1.25	#6	418-**-**
	1.50	3.00	2.56	1.00	2.00	10.00	1.00	5.06	3.69	1.50	1.50	#6	420-**-**
3.00	1.25	3.50	2.81	1.00	2.00	10.25	1.00	5.25	3.75	1.25	1.25	#8	424-**-**
	1.50	3.50	2.69	1.00	2.00	10.25	1.00	5.12	3.88	1.50	1.50	#8	426-**-**
	1.75	3.50	2.69	1.00	2.00	10.25	1.00	5.12	3.88	1.75	1.75	#8	428-**-**
	2.00	3.50	2.69	1.00	2.00	10.50	1.00	5.38	3.88	2.00	2.00	#8	430-**-**
3.50	1.50	4.00	3.06	1.25	2.50	11.25	1.25	5.50	4.50	1.50	1.50	#8	434-**-**
	1.75	4.00	3.06	1.25	2.50	11.25	1.25	5.50	4.50	1.75	1.75	#8	436-**-**
	2.00	4.00	3.06	1.25	2.50	11.25	1.25	5.50	4.50	2.00	2.00	#8	438-**-**
4.00	1.50	4.50	3.19	1.25	2.50	11.50	1.25	5.62	4.62	1.50	1.50	#8	442-**-**
	1.75	4.50	3.25	1.25	2.50	11.75	1.25	5.69	4.81	1.75	1.75	#8	444-**-**
	2.00	4.50	3.25	1.25	2.50	11.75	1.25	5.69	4.81	2.00	2.00	#8	446-**-**
	2.50	4.50	3.25	1.25	2.50	12.00	1.25	5.94	4.81	2.50	2.50	#8	448-**-**
4.50	1.75	5.00	3.12	1.25	2.50	12.00	1.25	5.56	4.94	1.75	1.75	#8	452-**-**
	2.00	5.00	3.12	1.25	2.50	12.00	1.25	5.56	4.94	2.00	2.00	#8	454-**-**
	2.25	5.00	3.12	1.25	2.50	12.00	1.25	5.56	4.94	2.50	2.50	#8	456-**-**
5.00	2.00	5.62	3.25	1.50	2.50	12.50	1.50	5.69	5.31	2.00	2.00	#8	460-**-**
	2.50	5.62	3.25	1.50	2.50	12.75	1.50	5.94	5.31	2.50	2.50	#8	462-**-**
	3.00	5.62	3.25	1.50	2.50	12.75	1.50	5.94	5.31	3.00	3.00	#8	464-**-**

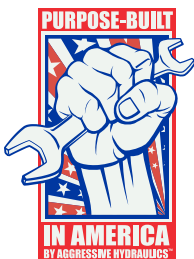

ORDERING INFORMATION

All Pre-Engineered Cylinders are manufactured in the U.S.A. and are backed by the Aggressive Hydraulics Cylinder Warranty.

- To complete part #, replace (**)** with stroke required.
- Maximum allowable stroke length for a given model is dependent on the actual maximum operating pressure and compressive load. Buckling strength limit for a cylinder will be calculated at the time of initial order or upon customer request.
- Customized options available upon request.

© AGGRESSIVE HYDRAULICS • WE'RE SIMPLY A PHONE CALL AWAY

PHONE: 763-792-4000 • EMAIL: SALES@AGGRESSIVEHYDRAULICS.COM • WEB: WWW.AGGRESSIVEHYDRAULICS.COM

600 SERIES

HEAVY-DUTY

PRE-ENGINEERED HYDRAULIC CYLINDERS

600 SERIES FEATURES:

- 3,000 psi heavy-duty type
- Cold drawn (high impact) 75 ksi min. yield D.O.M. tubing
- Ground & polished, hard chrome plated rods (75 ksi min. yield)
- Welded style construction certified to A.W.S. B2.1
- Internally threaded head design with buttress threads
- Highest quality seal configurations compatible with petroleum base fluids
- Increased bearing length on both head & piston
- Ductile iron head gland & piston
- Piston & head utilize wear bearings
- Nylon inserted lock nut
- Black primer

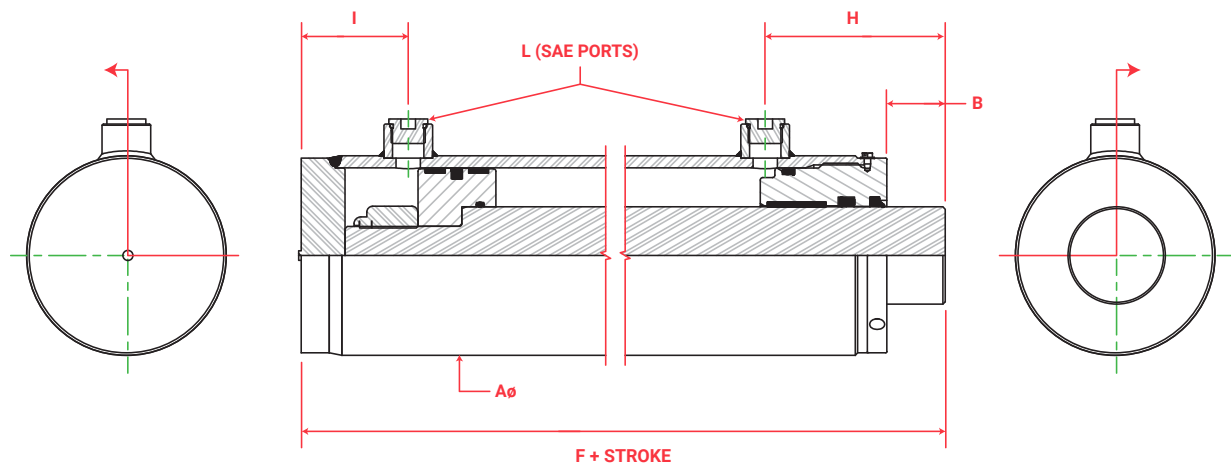

Pre-Engineered Cylinder Drawing Program

Instantly customize and print detailed drawings of our
600 Series Pre-Engineered Cylinders

600 SERIES CYLINDERS

Bore	Rod	A	B	F	H	I	L	Part #
3.00	1.75	3.50	1.56	8.25	3.94	1.94	#6	604-**-**
	2.00	3.50	1.56	8.25	3.94	1.94	#6	606-**-**
3.50	1.75	4.00	1.44	8.25	3.88	2.00	#8	610-**-**
	2.00	4.00	1.50	8.50	3.94	2.19	#8	612-**-**
4.00	2.00	4.62	1.50	9.25	4.56	2.31	#8	616-**-**
	2.50	4.62	1.50	9.25	4.56	2.31	#8	618-**-**
	3.00	4.62	1.62	10.00	5.44	2.56	#8	620-**-**
4.50	2.00	5.12	1.50	9.50	4.62	2.50	#10	624-**-**
	2.50	5.12	1.50	9.75	4.62	2.75	#10	626-**-**
	3.00	5.12	1.50	9.75	4.62	2.75	#10	628-**-**
	3.50	5.12	1.50	10.00	5.38	2.62	#10	630-**-**
5.00	2.00	5.62	1.50	9.25	4.44	2.44	#12	634-**-**
	2.50	5.62	1.62	10.25	5.00	2.69	#12	636-**-**
	3.00	5.62	1.62	10.25	5.00	2.69	#12	638-**-**
	3.50	5.62	1.50	10.00	4.88	2.56	#12	640-**-**
	4.00	5.62	1.62	10.25	5.56	2.69	#12	642-**-**
5.50	2.50	6.12	1.44	10.25	4.81	2.75	#12	646-**-**
	3.00	6.12	1.56	10.25	4.94	2.62	#12	648-**-**
	3.50	6.12	1.56	10.25	4.94	2.62	#12	650-**-**
	4.00	6.12	1.69	10.50	5.06	2.75	#12	652-**-**
	4.50	6.12	1.56	11.00	5.50	3.38	#12	654-**-**
6.00	2.50	6.75	1.62	10.50	5.00	2.81	#12	658-**-**
	3.00	6.75	1.50	10.25	4.88	2.69	#12	660-**-**
	3.50	6.75	1.50	10.25	4.88	2.69	#12	662-**-**
	4.00	6.75	1.62	10.50	5.00	2.81	#12	664-**-**
7.00	2.50	8.00	1.69	11.25	5.62	2.75	#16	668-**-**
	3.00	8.00	1.69	11.25	5.62	2.75	#16	670-**-**
	3.50	8.00	1.69	11.25	5.62	2.75	#16	672-**-**
	4.00	8.00	1.56	11.75	5.50	3.38	#16	674-**-**
8.00	3.50	9.00	1.50	13.00	5.69	3.44	#16	678-**-**
	4.00	9.00	1.50	13.00	5.69	3.44	#16	680-**-**
	4.50	9.00	1.50	13.00	5.69	3.44	#16	682-**-**

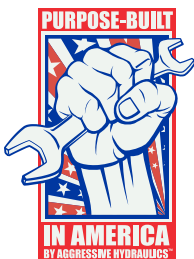

ORDERING INFORMATION

All Pre-Engineered Cylinders are manufactured in the U.S.A. and are backed by the Aggressive Hydraulics Cylinder Warranty.

- To complete part #, replace (**)** with stroke required.
- Maximum allowable stroke length for a given model is dependent on the actual maximum operating pressure and compressive load. Buckling strength limit for a cylinder will be calculated at the time of initial order or upon customer request.
- Customized options available upon request.

© AGGRESSIVE HYDRAULICS • WE'RE SIMPLY A PHONE CALL AWAY

PHONE: 763-792-4000 • EMAIL: SALES@AGGRESSIVEHYDRAULICS.COM • WEB: WWW.AGGRESSIVEHYDRAULICS.COM

700 SERIES

HEAVY-DUTY

PRE-ENGINEERED HYDRAULIC CYLINDERS

700 SERIES FEATURES:

- Cross tube style base and rod mounts
- 3,000 psi heavy-duty type
- Cold drawn (high impact) 75 ksi min. yield D.O.M. tubing
- Ground & polished, hard chrome plated rods (75 ksi min. yield)
- Welded style construction certified to A.W.S. B2.1
- Internally threaded head design with buttress threads
- Highest quality seal configurations compatible with petroleum base fluids
- Increased bearing length on both head & piston
- Ductile iron head gland & piston
- Piston & head utilize wear bearings
- Nylon inserted lock nut
- Black primer

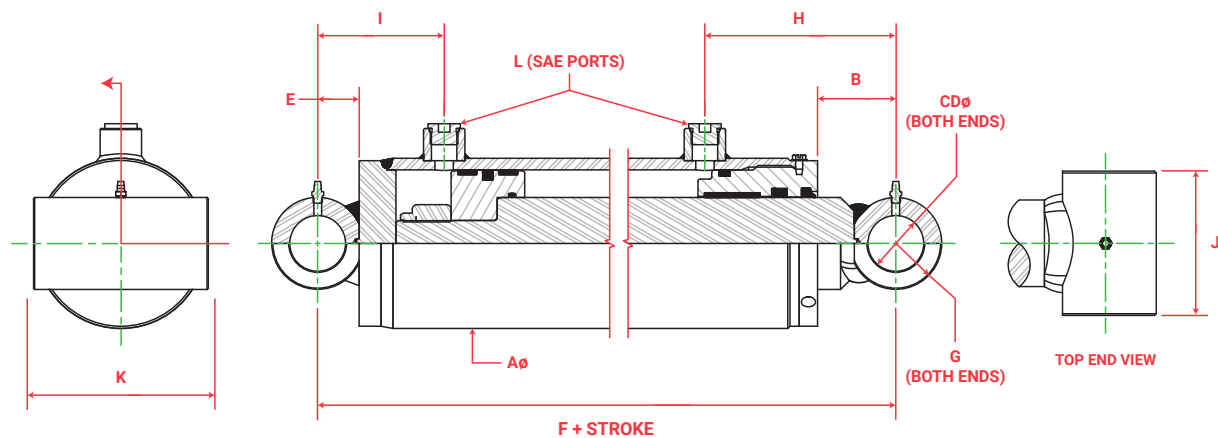

Pre-Engineered Cylinder Drawing Program

Instantly customize and print detailed drawings of our
700 Series Pre-Engineered Cylinders

700 SERIES CYLINDERS

Bore	Rod	A	B	CD	E	F	G	H	I	J	K	L	Part #
3.00	1.75	3.50	1.50	1.000	.81	9.00	.88	3.88	2.75	2.75	3.75	#6	704-**-**
	2.00	3.50	1.50	1.000	.81	9.00	.88	3.88	2.75	2.75	3.75	#6	706-**-**
3.50	1.75	4.00	1.56	1.250	.88	9.25	1.00	4.00	2.88	3.25	4.25	#8	710-**-**
	2.00	4.00	1.62	1.250	.88	9.50	1.00	4.06	3.06	3.25	4.25	#8	712-**-**
4.00	2.00	4.62	2.12	1.500	1.12	11.00	1.25	5.19	3.44	3.00	4.75	#8	716-**-**
	2.50	4.62	2.12	1.500	1.12	11.00	1.25	5.19	3.44	3.00	4.75	#8	718-**-**
	3.00	4.62	2.00	1.500	1.12	11.50	1.25	5.81	3.69	4.25	4.75	#8	720-**-**
4.50	2.00	5.12	1.88	1.500	1.12	11.00	1.25	5.00	3.62	3.00	5.50	#10	724-**-**
	2.50	5.12	2.12	1.500	1.12	11.50	1.25	5.25	3.88	3.00	5.50	#10	726-**-**
	3.00	5.12	2.12	1.500	1.12	11.50	1.25	5.25	3.88	4.25	5.50	#10	728-**-**
	3.50	5.12	2.12	1.500	1.12	11.75	1.25	6.00	3.75	4.25	5.50	#10	730-**-**
5.00	2.00	5.62	2.25	1.750	1.25	11.25	1.38	5.19	3.69	3.25	6.00	#12	734-**-**
	2.50	5.62	2.12	1.750	1.25	12.00	1.38	5.50	3.94	3.25	6.00	#12	736-**-**
	3.00	5.62	2.12	1.750	1.25	12.00	1.38	5.50	3.94	4.75	6.00	#12	738-**-**
	3.50	5.62	2.00	1.750	1.25	11.75	1.38	5.38	3.81	4.75	6.00	#12	740-**-**
	4.00	5.62	2.12	1.750	1.25	12.00	1.38	6.06	3.94	4.75	6.00	#12	742-**-**
5.50	2.50	6.12	2.19	1.750	1.25	12.25	1.38	5.56	4.00	3.25	7.00	#12	746-**-**
	3.00	6.12	2.06	1.750	1.25	12.00	1.38	5.44	3.88	4.75	7.00	#12	748-**-**
	3.50	6.12	2.06	1.750	1.25	12.00	1.38	5.44	3.88	4.75	7.00	#12	750-**-**
	4.00	6.12	2.19	1.750	1.25	12.25	1.38	5.56	4.00	4.75	7.00	#12	752-**-**
	4.50	6.12	2.06	1.750	1.25	12.75	1.38	6.00	4.62	5.50	7.00	#12	754-**-**
6.00	2.50	6.75	2.25	2.000	1.38	12.50	1.50	5.62	4.19	3.50	7.00	#12	758-**-**
	3.00	6.75	2.12	2.000	1.38	12.25	1.50	5.50	4.06	3.50	7.00	#12	760-**-**
	3.50	6.75	2.12	2.000	1.38	12.25	1.50	5.50	4.06	4.75	7.00	#12	762-**-**
	4.00	6.75	2.25	2.000	1.38	12.50	1.50	5.62	4.19	5.50	7.00	#12	764-**-**
7.00	2.50	8.00	2.81	2.500	1.62	14.00	1.75	6.75	4.38	5.00	8.25	#16	768-**-**
	3.00	8.00	2.81	2.500	1.62	14.00	1.75	6.75	4.38	5.00	8.25	#16	770-**-**
	3.50	8.00	2.81	2.500	1.62	14.00	1.75	6.75	4.38	5.00	8.25	#16	772-**-**
	4.00	8.00	2.69	2.500	1.62	14.50	1.75	6.62	5.00	5.00	8.25	#16	774-**-**
8.00	3.50	9.00	2.88	3.000	1.88	16.25	2.00	7.06	5.31	5.00	9.25	#16	778-**-**
	4.00	9.00	2.88	3.000	1.88	16.25	2.00	7.06	5.31	5.00	9.25	#16	780-**-**
	4.50	9.00	2.88	3.000	1.88	16.25	2.00	7.06	5.31	5.00	9.25	#16	782-**-**

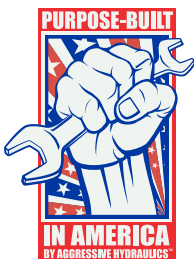

ORDERING INFORMATION

All Pre-Engineered Cylinders are manufactured in the U.S.A. and are backed by the Aggressive Hydraulics Cylinder Warranty.

- To complete part #, replace (**)** with stroke required.
- Maximum allowable stroke length for a given model is dependent on the actual maximum operating pressure and compressive load. Buckling strength limit for a cylinder will be calculated at the time of initial order or upon customer request.
- Customized options available upon request.

800 SERIES

HEAVY-DUTY

PRE-ENGINEERED HYDRAULIC CYLINDERS

800 SERIES FEATURES:

- Clevis style base and rod mounts
- 3,000 psi heavy-duty type
- Cold drawn (high impact) 75 ksi min. yield D.O.M. tubing
- Ground & polished, hard chrome plated rods (75 ksi min. yield)
- Welded style construction certified to A.W.S. B2.1
- Internally threaded head design with buttress threads
- Highest quality seal configurations compatible with petroleum base fluids
- Increased bearing length on both head & piston
- Ductile iron head gland & piston
- Piston & head utilize wear bearings
- Nylon inserted lock nut
- Black primer

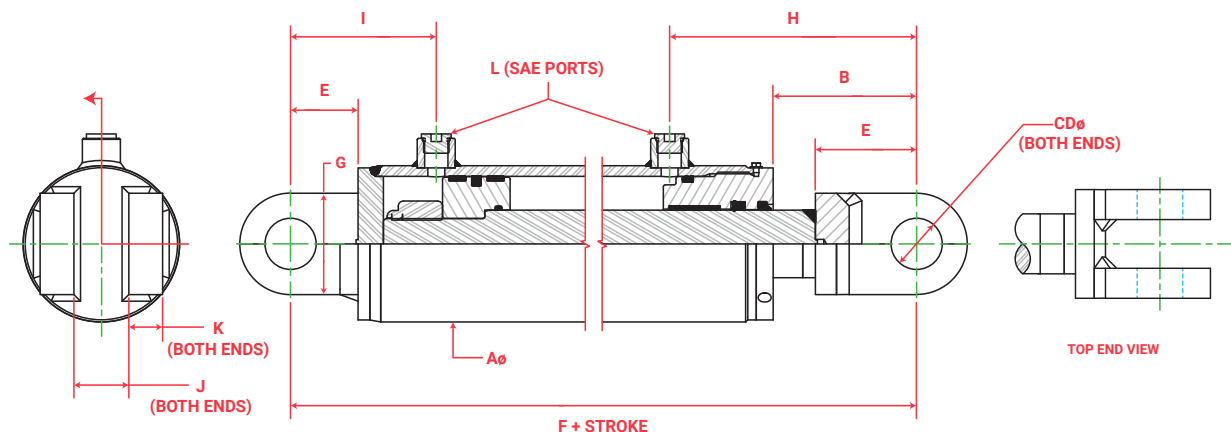

Pre-Engineered Cylinder Drawing Program

Instantly customize and print detailed drawings of our
800 Series Pre-Engineered Cylinders

800 SERIES CYLINDERS

Bore	Rod	A	B	CD	E	F	G	H	I	J	K	L	Part #
3.00	1.75	3.50	3.31	1.000	2.00	12.00	2.00	5.75	3.94	1.25	.50	#6	804-**-**
	2.00	3.50	3.31	1.000	2.00	12.00	2.00	5.75	3.94	1.25	.50	#6	806-**-**
3.50	1.75	4.00	3.81	1.250	2.00	12.50	2.50	6.31	4.00	1.62	.75	#8	810-**-**
	2.00	4.00	3.50	1.250	2.00	12.50	2.50	5.94	4.00	1.62	.75	#8	812-**-**
4.00	2.00	4.62	4.25	1.500	2.00	14.00	3.00	7.31	4.31	1.62	1.00	#8	816-**-**
	2.50	4.62	4.25	1.500	2.00	14.00	3.00	7.31	4.31	1.62	1.00	#8	818-**-**
	3.00	4.62	4.12	1.500	2.00	14.50	3.00	7.94	4.56	1.62	1.00	#8	820-**-**
4.50	2.00	5.12	4.25	1.500	2.00	14.25	3.00	7.38	4.50	1.62	1.00	#10	824-**-**
	2.50	5.12	4.00	1.500	2.00	14.25	3.00	7.12	4.75	1.62	1.00	#10	826-**-**
	3.00	5.12	4.00	1.500	2.00	14.25	3.00	7.12	4.75	1.62	1.00	#10	828-**-**
	3.50	5.12	4.00	1.500	2.00	14.50	3.00	7.88	4.62	1.62	1.00	#10	830-**-**
5.00	2.00	5.62	4.25	1.750	2.25	14.25	3.50	7.19	4.69	2.12	1.00	#12	834-**-**
	2.50	5.62	4.12	1.750	2.25	15.00	3.50	7.50	4.94	2.12	1.00	#12	836-**-**
	3.00	5.62	4.12	1.750	2.25	15.00	3.50	7.50	4.94	2.12	1.00	#12	838-**-**
	3.50	5.62	4.25	1.750	2.25	15.00	3.50	7.62	4.81	2.12	1.00	#12	840-**-**
	4.00	5.62	4.12	1.750	2.25	15.00	3.50	8.06	4.94	2.12	1.00	#12	842-**-**
5.50	2.50	6.12	4.44	1.750	2.25	15.50	3.50	7.81	5.00	2.12	1.25	#12	846-**-**
	3.00	6.12	4.56	1.750	2.25	15.50	3.50	7.94	4.88	2.12	1.25	#12	848-**-**
	3.50	6.12	4.56	1.750	2.25	15.50	3.50	7.94	4.88	2.12	1.25	#12	850-**-**
	4.00	6.12	4.44	1.750	2.25	15.50	3.50	7.81	5.00	2.12	1.25	#12	852-**-**
	4.50	6.12	4.56	1.750	2.25	16.25	3.50	8.50	5.63	2.12	1.25	#12	854-**-**
6.00	2.50	6.75	4.62	2.000	2.50	16.00	4.00	8.00	5.31	2.62	1.25	#12	858-**-**
	3.00	6.75	4.50	2.000	2.50	15.75	4.00	7.88	5.19	2.62	1.25	#12	860-**-**
	3.50	6.75	4.50	2.000	2.50	15.75	4.00	7.88	5.19	2.62	1.25	#12	862-**-**
	4.00	6.75	4.62	2.000	2.50	16.00	4.00	8.00	5.31	2.62	1.25	#12	864-**-**
7.00	2.50	8.00	5.19	2.500	3.00	17.75	5.00	9.12	5.75	2.62	1.25	#16	868-**-**
	3.00	8.00	5.19	2.500	3.00	17.75	5.00	9.12	5.75	2.62	1.25	#16	870-**-**
	3.50	8.00	5.19	2.500	3.00	17.75	5.00	9.12	5.75	2.62	1.25	#16	872-**-**
	4.00	8.00	5.06	2.500	3.00	18.25	5.00	9.00	6.38	2.62	1.25	#16	874-**-**
8.00	3.50	9.00	6.50	3.000	4.00	22.00	6.00	10.69	7.44	3.12	1.50	#16	878-**-**
	4.00	9.00	6.50	3.000	4.00	22.00	6.00	10.69	7.44	3.12	1.50	#16	880-**-**
	4.50	9.00	6.50	3.000	4.00	22.00	6.00	10.69	7.44	3.12	1.50	#16	882-**-**

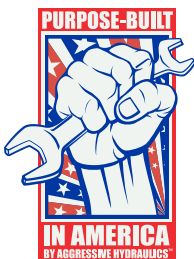

ORDERING INFORMATION

All Pre-Engineered Cylinders are manufactured in the U.S.A. and are backed by the Aggressive Hydraulics Cylinder Warranty.

- To complete part #, replace (**)** with stroke required.
- Maximum allowable stroke length for a given model is dependent on the actual maximum operating pressure and compressive load. Buckling strength limit for a cylinder will be calculated at the time of initial order or upon customer request.
- Customized options available upon request.

900 SERIES

HEAVY-DUTY

PRE-ENGINEERED HYDRAULIC CYLINDERS

900 SERIES FEATURES:

- Spherical bearing mounts on both ends for proper alignment
- 3,000 psi heavy-duty type
- Cold drawn (high impact) 75 ksi min. yield D.O.M. tubing
- Ground & polished, hard chrome plated rods (75 ksi min. yield)
- Welded style construction certified to A.W.S. B2.1
- Internally threaded head design with buttress threads
- Highest quality seal configurations compatible with petroleum base fluids
- Increased bearing length on both head & piston
- Ductile iron head gland & piston
- Piston & head utilize wear bearings
- Nylon inserted lock nut
- Black primer

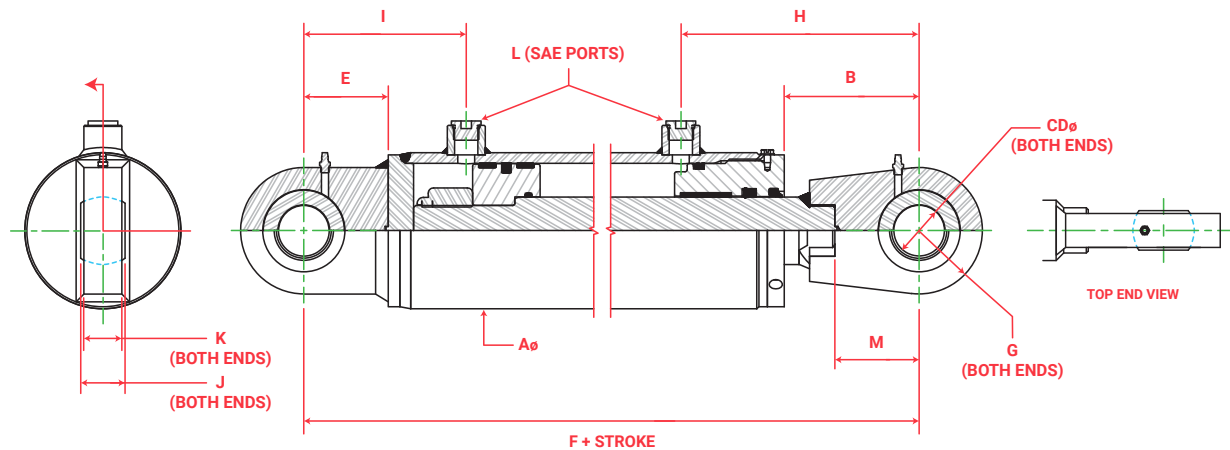

Pre-Engineered Cylinder Drawing Program

Instantly customize and print detailed drawings of our
900 Series Pre-Engineered Cylinders

900 SERIES CYLINDERS

Bore	Rod	A	B	CD	E	F	G	H	I	J	K	L	M	Part #
3.00	1.75	3.50	3.81	1.250	2.00	12.50	1.50	6.19	3.94	1.093	.94	#6	2.00	904-**-**
	2.00	3.50	3.81	1.250	2.00	12.50	1.50	6.19	3.94	1.093	.94	#6	2.00	906-**-**
3.50	1.75	4.00	3.94	1.250	2.00	12.75	1.50	6.38	4.00	1.093	.94	#8	2.00	910-**-**
	2.00	4.00	3.75	1.250	2.00	12.75	1.50	6.19	4.19	1.093	.94	#8	2.00	912-**-**
4.00	2.00	4.62	4.00	1.500	2.50	14.25	1.88	7.06	4.81	1.312	1.12	#8	2.25	916-**-**
	2.50	4.62	4.00	1.500	2.50	14.25	1.88	7.06	4.81	1.312	1.12	#8	2.25	918-**-**
	3.00	4.62	4.12	1.500	2.50	15.00	1.88	7.94	5.06	1.312	1.12	#8	2.25	920-**-**
4.50	2.00	5.12	4.00	1.500	2.50	14.50	1.88	7.12	5.00	1.312	1.12	#10	2.25	924-**-**
	2.50	5.12	4.00	1.500	2.50	14.75	1.88	7.12	5.25	1.312	1.12	#10	2.25	926-**-**
	3.00	5.12	4.00	1.500	2.50	14.75	1.88	7.12	5.25	1.312	1.12	#10	2.25	928-**-**
	3.50	5.12	4.00	1.500	2.50	15.00	1.88	7.88	5.12	1.312	1.12	#10	2.25	930-**-**
5.00	2.00	5.62	4.50	1.750	2.50	14.75	2.00	7.44	4.94	1.531	1.31	#12	2.50	934-**-**
	2.50	5.62	4.62	1.750	2.50	15.75	2.00	8.00	5.19	1.531	1.31	#12	2.50	936-**-**
	3.00	5.62	4.62	1.750	2.50	15.75	2.00	8.00	5.19	1.531	1.31	#12	2.50	938-**-**
	3.50	5.62	4.50	1.750	2.50	15.50	2.00	7.88	5.06	1.531	1.31	#12	2.50	940-**-**
	4.00	5.62	4.62	1.750	2.50	15.75	2.00	8.56	5.19	1.531	1.31	#12	2.50	942-**-**
5.50	2.50	6.12	4.69	1.750	2.50	16.00	2.00	8.06	5.25	1.531	1.31	#12	2.50	946-**-**
	3.00	6.12	4.56	1.750	2.50	15.75	2.00	7.94	5.12	1.531	1.31	#12	2.50	948-**-**
	3.50	6.12	4.56	1.750	2.50	15.75	2.00	7.94	5.12	1.531	1.31	#12	2.50	950-**-**
	4.00	6.12	4.69	1.750	2.50	16.00	2.00	8.06	5.25	1.531	1.31	#12	2.50	952-**-**
	4.50	6.12	4.56	1.750	2.50	16.50	2.00	8.50	5.88	1.531	1.31	#12	2.50	954-**-**
6.00	2.50	6.75	4.88	2.000	2.75	16.50	2.38	8.25	5.56	1.750	1.50	#12	2.75	958-**-**
	3.00	6.75	4.75	2.000	2.75	16.25	2.38	8.12	5.44	1.750	1.50	#12	2.75	960-**-**
	3.50	6.75	4.75	2.000	2.75	16.25	2.38	8.12	5.44	1.750	1.50	#12	2.75	962-**-**
	4.00	6.75	4.88	2.000	2.75	16.50	2.38	8.25	5.56	1.750	1.50	#12	2.25	964-**-**
7.00	2.50	8.00	5.69	2.500	3.25	18.50	3.00	9.62	6.00	2.188	1.88	#16	3.25	968-**-**
	3.00	8.00	5.69	2.500	3.25	18.50	3.00	9.62	6.00	2.188	1.88	#16	3.25	970-**-**
	3.50	8.00	5.69	2.500	3.25	18.50	3.00	9.62	6.00	2.188	1.88	#16	3.25	972-**-**
	4.00	8.00	5.56	2.500	3.25	19.00	3.00	9.50	6.62	2.188	1.88	#16	3.25	974-**-**
8.00	3.50	9.00	6.50	3.000	4.25	22.25	3.75	10.69	7.69	2.625	2.25	#16	4.25	978-**-**
	4.00	9.00	6.50	3.000	4.25	22.25	3.75	10.69	7.69	2.625	2.25	#16	4.25	980-**-**
	4.50	9.00	6.50	3.000	4.25	22.25	3.75	10.69	7.69	2.625	2.25	#16	4.25	982-**-**

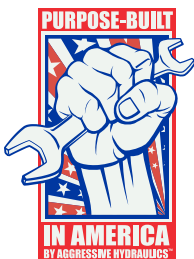

ORDERING INFORMATION

All Pre-Engineered Cylinders are manufactured in the U.S.A. and are backed by the Aggressive Hydraulics Cylinder Warranty.

- To complete part #, replace (**)** with stroke required.
- Maximum allowable stroke length for a given model is dependent on the actual maximum operating pressure and compressive load. Buckling strength limit for a cylinder will be calculated at the time of initial order or upon customer request.
- Customized options available upon request.



COMPONENT PARTS

Trusted for the toughest jobs and applications

The design and integrity of our parts have taken years to refine and perfect. Our standard parts are in stock at all times, allowing you to minimize your downtime. Let our design expertise, industry knowledge, state-of-the-art manufacturing techniques and on-hand inventory become your advantage.



TK HEAD

- Material: 65-45-12 ductile iron
- Retained in case (barrel, body, main) with wind in lock ring

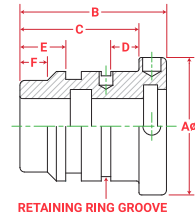

Part Number	Bore +.003" - .003"	Rod +.000" - .003"	A	B	C	D	E	F	Seal Kit Number	Lock Ring Number
H70181	1.500	0.750	1.88	2.00	1.63	0.38	0.63	0.38	SKH70181	RR20030
H70184	1.500	1.000	1.88	2.00	1.12	0.31	0.19	N/A	SKH70184	RR20030
H70093	2.000	1.000	2.38	2.25	1.88	0.44	0.75	0.50	SKH70093	RR20029
H70159	2.000	1.125	2.38	2.25	1.88	0.44	0.75	0.44	SKH70159	RR20029
H70160	2.000	1.250	2.38	2.50	1.88	0.44	0.75	0.44	SKH70160	RR20029
H70161	2.500	1.125	2.88	2.25	1.88	0.44	0.75	0.44	SKH70161	RR20031
H70162	2.500	1.250	2.88	2.25	1.88	0.44	0.75	0.38	SKH70162	RR20031
H70163	2.500	1.500	2.88	2.25	1.88	0.44	0.75	0.62	SKH70163	RR20031
H70861	2.500	1.750	2.88	2.50	1.88	0.44	0.75	0.38	SKH70861	RR20031
H70164	3.000	1.250	3.38	2.75	2.25	0.51	0.88	0.50	SKH70164	RR20027
H70130	3.000	1.500	3.38	2.75	2.25	0.51	0.88	0.50	SKH70130	RR20027
H70560	3.000	1.750	3.38	2.75	2.25	0.51	0.88	0.44	SKH70560	RR20027
H70165	3.000	2.000	3.38	2.75	2.25	0.51	0.88	0.44	SKH70165	RR20027
H70166	3.500	1.250	3.88	2.75	2.25	0.51	0.88	0.50	SKH70166	RR20032
H70089	3.500	1.500	3.88	2.75	2.25	0.51	0.88	0.50	SKH70089	RR20032
H70862	3.500	1.750	3.88	2.75	2.25	0.51	0.88	0.50	SKH70862	RR20032
H70167	3.500	2.000	3.88	2.75	2.25	0.51	0.88	0.50	SKH70167	RR20032
H70115	4.000	1.500	4.50	2.75	2.25	0.44	0.88	0.44	SKH70115	RR20033
H70576	4.000	1.750	4.50	2.75	2.25	0.44	0.88	0.44	SKH70576	RR20033
H70116	4.000	2.000	4.50	2.75	2.25	0.44	0.88	0.44	SKH70116	RR20033
H70168	4.000	2.500	4.50	2.75	2.25	0.44	0.88	0.44	SKH70168	RR20033
H70367	4.500	2.000	5.00	2.75	2.25	0.44	0.88	0.44	SKH70367	RR20087
H70378	4.500	2.500	5.00	2.75	2.25	0.44	0.88	0.44	SKH70378	RR20087
H70379	4.500	3.000	5.00	2.75	2.25	0.44	0.88	0.44	SKH70379	RR20087
H70114	5.000	2.000	5.50	3.00	2.50	0.56	0.94	0.50	SKH70114	RR20039
H70113	5.000	2.500	5.50	3.00	2.50	0.56	0.94	0.50	SKH70113	RR20039
H70107	5.000	3.000	5.50	3.00	2.50	0.56	0.94	0.50	SKH70107	RR20039
H70389	5.500	2.000	6.00	3.00	2.50	0.56	0.94	0.50	SKH70389	RR20089
H70390	5.500	2.500	6.00	3.00	2.50	0.56	0.94	0.50	SKH70390	RR20089
H70391	5.500	3.000	6.00	3.00	2.50	0.56	0.94	0.50	SKH70391	RR20089
H70112	6.000	2.000	6.50	3.00	2.50	0.56	0.94	0.50	SKH70112	RR20040
H70111	6.000	2.500	6.50	3.00	2.50	0.56	0.94	0.50	SKH70111	RR20040
H70108	6.000	3.000	6.50	3.00	2.50	0.56	0.94	0.50	SKH70108	RR20040

TK Retaining Groove Technical Information

Bore +.003" - .003"	H	J	K	L +.010" - .000"	M +.005" - .000"	N +.000" - .005"
1.500	0.25	0.25	0.28	1.625	0.125	0.375*
2.000	0.25	0.25	0.34	2.125	0.125	0.438
2.500	0.25	0.25	0.34	2.625	0.125	0.438
3.000	0.25	0.25	0.41	3.125	0.125	0.500
3.500	0.25	0.25	0.41	3.625	0.125	0.500
4.000	0.38	0.25	0.41	4.188	0.188	0.438
4.500	0.38	0.25	0.41	4.688	0.188	0.438
5.000	0.38	0.25	0.53	5.188	0.188	0.562
5.500	0.38	0.25	0.53	5.688	0.188	0.562
6.000	0.38	0.25	0.53	6.188	0.188	0.562

*0.312 FOR 1" ROD

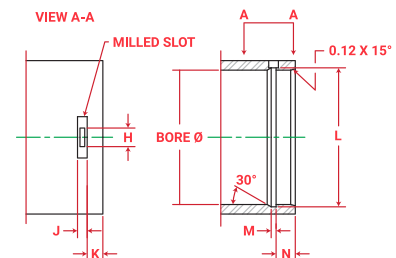

TH HEAD

- Material: 65-45-12 ductile iron
- Slides into case (barrel, body, main)
- Retained with TH Gland Cap

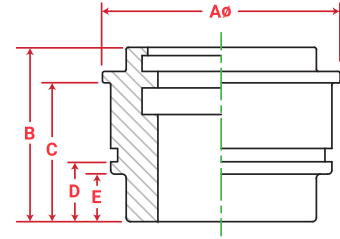

Part Number	Bore $+.003''$ $-.003''$	Rod $+.000''$ $-.003''$	A	B	C	D	E	Seal Kit Number
H70154	2.000	1.000	2.25	2.38	1.93	0.81	0.62	SKH70154
H70155	2.000	1.125	2.25	2.38	1.93	0.81	0.62	SKH70155
H70156	2.000	1.250	2.25	2.38	1.93	0.81	0.62	SKH70156
H70157	2.500	1.125	2.75	2.38	1.93	0.81	0.62	SKH70157
H70076	2.500	1.250	2.75	2.38	1.93	0.81	0.62	SKH70076
H70158	2.500	1.500	2.75	2.38	1.93	0.81	0.62	SKH70158
H70462	2.500	1.750	2.75	2.38	2.19	0.81	0.62	SKH70462
H70029	3.000	1.250	3.25	2.75	2.19	0.93	0.75	SKH70029
H70011	3.000	1.500	3.25	2.75	2.19	0.93	0.75	SKH70011
H70814	3.000	1.750	3.25	2.75	2.19	0.93	0.75	SKH70814
H70012	3.000	2.000	3.25	2.75	2.56	0.93	0.69	SKH70012
H70013	3.500	1.500	3.75	2.75	2.19	0.93	0.75	SKH70013
H70504	3.500	1.750	3.75	2.75	2.19	0.93	0.75	SKH70504
H70030	3.500	2.000	3.75	2.75	2.19	0.93	0.75	SKH70030
H70031	3.500	2.500	3.75	2.75	2.56	0.93	0.75	SKH70031
H70014	4.000	1.500	4.25	2.75	2.19	0.93	0.75	SKH70014
H70488	4.000	1.750	4.25	2.75	2.19	0.93	0.75	SKH70488
H70015	4.000	2.000	4.25	2.75	2.19	0.93	0.75	SKH70015
H70032	4.000	2.500	4.25	2.75	2.19	0.93	0.75	SKH70032
H70033	4.000	3.000	4.25	2.75	2.56	0.93	0.75	SKH70033
H70276	4.500	2.000	4.75	2.75	2.19	0.93	0.75	SKH70276
H70310	4.500	2.500	4.75	2.75	2.19	0.93	0.75	SKH70310
H70377	4.500	3.000	4.75	2.75	2.19	0.93	0.75	SKH70377
H70037	5.000	2.000	5.38	3.00	2.44	1.12	0.88	SKH70037
H70038	5.000	2.500	5.38	3.00	2.44	1.12	0.88	SKH70038
H70039	5.000	3.000	5.38	3.00	2.44	1.12	0.88	SKH70039
H70153	5.500	2.000	5.88	3.00	2.44	1.12	0.88	SKH70153
H70142	5.500	2.500	5.88	3.00	2.44	1.12	0.88	SKH70142
H70143	5.500	3.000	5.88	3.00	2.44	1.12	0.88	SKH70143
H70041	6.000	2.000	6.38	3.00	2.44	1.12	0.88	SKH70041
H70042	6.000	2.500	6.38	3.00	2.44	1.12	0.88	SKH70042
H70043	6.000	3.000	6.38	3.00	2.44	1.12	0.88	SKH70043
H70180	7.000	2.500	7.50	4.00	3.12	1.75	1.50	SKH70180
H70176	7.000	3.000	7.50	4.00	3.12	1.75	1.50	SKH70176
H70186	7.000	3.500	7.50	4.00	3.12	1.75	1.50	SKH70186
H70133	8.000	3.000	8.50	4.00	3.12	1.75	1.50	SKH70133
H70195	8.000	3.500	8.50	4.00	3.12	1.75	1.50	SKH70195
H70217	8.000	4.000	8.50	4.00	3.12	1.75	1.50	SKH70217

TH GLAND CAP – HEAD NUT

- Material: 1026 CDS (cold drawn seamless mechanical tubing)
- Retains TH Head to case (barrel, body, main)

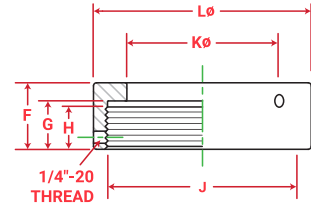

Part Number	Bore +003" - .003"	F	G	H	J Thread	K	L
HC70074	2.000	1.12	0.88	0.69	2-3/8"-12 UN-2B	1.81	3.00
HC70075	2.500	1.12	0.88	0.69	2-7/8"-12 UN-2B	2.31	3.50
HC70008	3.000	1.38	1.00	0.75	3-1/2"-12 UN-2B	2.63	4.00
HC70009	3.500	1.38	1.00	0.75	4"-12 UN-2B	3.12	4.50
HC70034	4.000	1.38	1.00	0.75	4-1/2"-12 UN-2B	3.62	5.00
HC70277	4.500	1.38	1.00	0.75	5"-12 UN-2B	4.12	5.50
HC70040	5.000	1.38	1.00	0.75	5-1/2"-12 UN-2B	4.62	6.25
HC70140	5.500	1.38	1.00	0.75	6"-12 UN-2B	5.12	6.75
HC70044	6.000	1.38	1.00	0.75	6-5/8"-12 UN-2B	5.62	7.50
HC70174	7.000	2.00	1.38	1.12	7-7/8"-12 UN-2B	6.12	9.00
HC70132	8.000	2.00	1.38	1.12	8-7/8"-12 UN-2B	7.12	10.00

TH CASE THREAD TECHNICAL INFORMATION

Bore +.003" - .003"	M	N Thread	Major Diameter	Pitch Diameter
2.000	0.81	2-3/8"-12 UN-2A	2.3731 / 2.3617	2.3191 / 2.3128
2.500	0.81	2-7/8"-12 UN-2A	2.8731 / 2.8617	2.8191 / 2.8127
3.000	1.00	3-1/2"-12 UN-2A	3.4981 / 3.4867	3.4440 / 3.4376
3.500	1.00	4"-12 UN-2A	3.9980 / 3.9866	3.9439 / 3.9374
4.000	1.00	4-1/2"-12 UN-2A	4.4980 / 4.4866	4.4439 / 4.4374
4.500	1.00	5"-12 UN-2A	4.9980 / 4.9866	4.9439 / 4.9372
5.000	1.00	5-1/2"-12 UN-2A	5.4980 / 5.4866	5.4439 / 5.4372
5.500	1.00	6"-12 UN-2A	5.9979 / 5.9865	5.9438 / 5.9369
6.000	1.00	6-5/8"-12 UN-2A	6.6229 / 6.6115	6.5688 / 6.5619
7.000	1.25	7-7/8"-12 UN-2A	7.8729 / 7.8615	7.8188 / 7.8119
8.000	1.25	8-7/8"-12 UN-2A	8.8729 / 8.8615	8.8188 / 8.8119

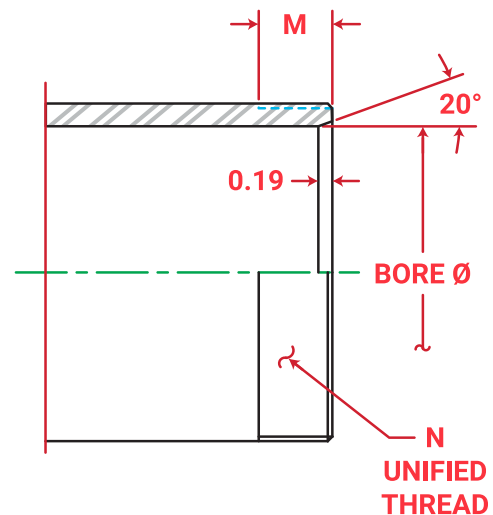

INTERNALLY THREADED HEAD – IT

- Material: 65-45-12 ductile iron
- Threads into case (barrel, body, main)
- Buttress thread design

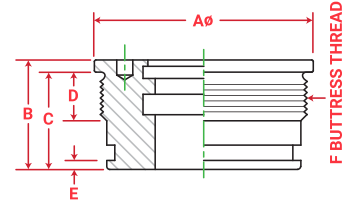

Part Number	Bore +.003" -.003"	Rod +.000" -.003"	A	B	C	D	E	Buttress F	Seal Kit Number
1070150075	1.500	0.750	2.00	1.75	1.50	0.75	0.16	1-3/4"-12	1080150075
1070150100	1.500	1.000	2.00	2.00	1.50	0.75	0.28	1-3/4"-12	1080150100
1070200100	2.000	1.000	2.50	2.12	1.93	1.00	0.12	2-1/4"-12	1080200100
1070200112	2.000	1.125	2.50	2.00	1.75	0.75	0.19	2-1/4"-12	1080200112
1070200125	2.000	1.250	2.50	2.25	2.00	1.00	0.19	2-1/4"-12	1080200125
1070250100	2.500	1.000	3.00	2.00	1.75	0.75	0.19	2-3/4"-12	1080250100
1070250112	2.500	1.125	3.00	2.00	1.75	0.75	0.19	2-3/4"-12	1080250112
1070250125	2.500	1.250	3.00	2.00	1.75	0.75	0.19	2-3/4"-12	1080250125
1070250150	2.500	1.500	3.00	2.38	2.00	1.00	0.19	2-3/4"-12	1080250150
1070250175	2.500	1.750	3.00	2.25	1.88	0.88	0.25	2-3/4"-12	1080250175
1070300100	3.000	1.000	3.50	2.25	2.00	1.00	0.19	3-1/4"-12	1080300100
1070300125	3.000	1.250	3.50	2.25	2.00	1.00	0.19	3-1/4"-12	1080300125
1070300138	3.000	1.375	3.50	2.25	2.00	1.00	0.19	3-1/4"-12	1080300138
1070300150	3.000	1.500	3.50	2.25	2.00	1.00	0.19	3-1/4"-12	1080300150
1070300175	3.000	1.750	3.50	2.25	2.00	1.00	0.19	3-1/4"-12	1080300175
1070300200	3.000	2.000	3.50	2.50	2.00	1.00	0.19	3-1/4"-12	1080300200
1070325125	3.250	1.250	3.75	2.25	2.00	1.00	0.19	3-1/2"-12	1080325125
1070325138	3.250	1.375	3.75	2.25	2.00	1.00	0.19	3-1/2"-12	1080325138
1070325150	3.250	1.500	3.75	2.25	2.00	1.00	0.19	3-1/2"-12	1080325150
1070325175	3.250	1.750	3.75	2.25	2.00	1.00	0.19	3-1/2"-12	1080325175
1070325200	3.250	2.000	3.75	2.25	2.00	1.00	0.19	3-1/2"-12	1080325200
1070350125	3.500	1.250	4.00	2.25	2.00	1.00	0.19	3-3/4"-12	1080350125
1070350150	3.500	1.500	4.00	2.25	2.00	1.00	0.19	3-3/4"-12	1080350150
1070350175	3.500	1.750	4.00	2.25	2.00	1.00	0.19	3-3/4"-12	1080350175
1070350200	3.500	2.000	4.00	2.25	2.00	1.00	0.19	3-3/4"-12	1080350200
1070350250	3.500	2.500	4.00	2.50	2.12	1.00	0.19	3-3/4"-12	1080350250
1070400150	4.000	1.500	4.50	2.25	2.00	1.00	0.19	4-1/4"-12	1080400150
1070400175	4.000	1.750	4.50	2.25	2.00	1.00	0.19	4-1/4"-12	1080400175
1070400200	4.000	2.000	4.50	2.25	2.00	1.00	0.19	4-1/4"-12	1080400200
1070400225	4.000	2.250	4.50	2.25	2.00	1.00	0.19	4-1/4"-12	1080400225
1070400250	4.000	2.500	4.50	2.50	2.12	1.12	0.19	4-1/4"-12	1080400250
1070400300	4.000	3.000	4.50	2.50	2.12	1.00	0.19	4-1/4"-12	1080400300
1070450175	4.500	1.750	5.00	2.25	2.00	1.00	0.19	4-3/4"-12	1080450175
1070450200	4.500	2.000	5.00	2.25	2.00	1.00	0.19	4-3/4"-12	1080450200
1070450225	4.500	2.250	5.00	2.25	2.00	1.00	0.19	4-3/4"-12	1080450225
1070450250	4.500	2.500	5.00	2.38	2.12	1.00	0.31	4-3/4"-12	1080450250
1070450350	4.500	3.500	5.00	2.38	2.00	1.00	0.19	4-3/4"-12	1080450350
1070500175	5.000	1.750	5.50	2.25	2.00	1.00	0.19	5-1/4"-12	1080500175
1070500200	5.000	2.000	5.50	2.25	2.00	1.00	0.19	5-1/4"-12	1080500200
1070500250	5.000	2.500	5.50	2.50	2.12	1.12	0.19	5-1/4"-12	1080500250
1070500300	5.000	3.000	5.50	2.50	2.12	1.12	0.19	5-1/4"-12	1080500300
1070600200	6.000	2.000	6.50	2.50	2.12	1.12	0.19	6-1/4"-12	1080600200
1070600250	6.000	2.500	6.50	2.50	2.12	1.12	0.19	6-1/4"-12	1080600250
1070600300	6.000	3.000	6.50	2.50	2.12	1.12	0.19	6-1/4"-12	1080600300
1070600350	6.000	3.500	6.50	2.50	2.12	1.12	0.19	6-1/4"-12	1080600350
1070700300	7.000	3.000	7.50	2.88	2.50	1.12	0.59	7-1/4"-10	1080700300
1070700350	7.000	3.500	7.50	2.88	2.50	1.12	0.59	7-1/4"-10	1080700350
1070700400	7.000	4.000	7.50	2.88	2.50	1.12	0.59	7-1/4"-10	1080700400
1070800400	8.000	4.000	8.50	3.75	3.25	1.50	0.88	8-1/4"-10	1080800400
1070800450	8.000	4.500	8.50	3.75	3.25	1.50	0.88	8-1/4"-10	1080800450
1070800500	8.000	5.000	8.50	3.75	3.25	1.50	0.88	8-1/4"-10	1080800500

INTERNALLY THREADED HEAD – WIDE – ITW

- Material: 65-45-12 ductile iron
- Threads into case (barrel, body, main) • Buttress thread design

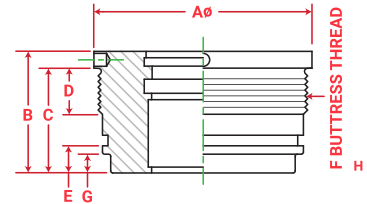

Part Number	Bore +.003" - .003"	Rod +.000" - .003"	A	B	C	D	E	Buttress F	G	Seal Kit Number
2070300175	3.000	1.750	3.50	2.62	2.25	1.00	0.56	3-1/4"-12	0.38	2080300175
2070300200	3.000	2.000	3.50	2.62	2.25	1.00	0.56	3-1/4"-12	0.38	2080300200
2070350175	3.500	1.750	4.00	2.62	2.25	1.00	0.56	3-3/4"-12	0.38	2080350175
2070350200	3.500	2.000	4.00	2.62	2.25	1.00	0.56	3-3/4"-12	0.38	2080350200
2070400200	4.000	2.000	4.50	3.25	2.75	1.25	0.56	4-1/4"-12	0.38	2080400200
2070400250	4.000	2.500	4.50	3.25	2.75	1.25	0.56	4-1/4"-12	0.38	2080400250
2070400300	4.000	3.000	4.50	3.62	3.12	1.38	0.19	4-1/4"-12	N/A	2080400300
2070450200	4.500	2.000	5.00	3.25	2.75	1.25	0.56	4-3/4"-12	0.38	2080450200
2070450250	4.500	2.500	5.00	3.25	2.75	1.25	0.56	4-3/4"-12	0.38	2080450250
2070450300	4.500	3.000	5.00	3.25	2.75	1.25	0.56	4-3/4"-12	0.38	2080450300
2070450350	4.500	3.500	5.00	3.62	3.12	1.38	0.19	4-3/4"-12	N/A	2080450350
2070500200	5.000	2.000	5.50	3.00	2.50	1.12	0.56	5-1/4"-12	0.38	2080500200
2070500250	5.000	2.500	5.50	3.62	3.12	1.38	0.81	5-1/4"-12	0.56	2080500250
2070500300	5.000	3.000	5.50	3.62	3.12	1.38	0.81	5-1/4"-12	0.56	2080500300
2070500350	5.000	3.500	5.50	3.62	3.12	1.38	0.81	5-1/4"-12	0.56	2080500350
2070500400	5.000	4.000	5.50	3.62	3.12	1.38	0.19	5-1/4"-12	N/A	2080500400
2070550250	5.500	2.500	6.00	3.62	3.12	1.38	0.81	5-3/4"-12	0.56	2080550250
2070550300	5.500	3.000	6.00	3.62	3.12	1.38	0.81	5-3/4"-12	0.56	2080550300
2070550350	5.500	3.500	6.00	3.62	3.12	1.38	0.81	5-3/4"-12	0.56	2080550350
2070550400	5.500	4.000	6.00	3.62	3.12	1.38	0.81	5-3/4"-12	0.56	2080550400
2070550450	5.500	4.500	6.00	3.62	3.12	1.38	0.19	5-3/4"-12	N/A	2080550450
2070600250	6.000	2.500	6.50	3.62	3.12	1.38	0.81	6-1/4"-12	0.56	2080600250
2070600300	6.000	3.000	6.50	3.62	3.12	1.38	0.81	6-1/4"-12	0.56	2080600300
2070600350	6.000	3.500	6.50	3.62	3.12	1.38	0.81	6-1/4"-12	0.56	2080600350
2070600400	6.000	4.000	6.50	3.62	3.12	1.38	0.81	6-1/4"-12	0.56	2080600400
2070600450	6.000	4.500	6.50	3.38	2.88	1.25	0.81	6-1/4"-12	0.62	2080600450
2070700250	7.000	2.500	7.50	4.25	3.75	1.50	1.03	7-1/4"-10	0.75	2080700250
2070700300	7.000	3.000	7.50	4.25	3.75	1.50	1.03	7-1/4"-10	0.75	2080700300
2070700350	7.000	3.500	7.50	4.25	3.75	1.50	1.03	7-1/4"-10	0.75	2080700350
2070700400	7.000	4.000	7.50	4.25	3.75	1.50	1.03	7-1/4"-10	0.75	2080700400
2070700450	7.000	4.500	7.50	4.25	3.75	1.50	1.03	7-1/4"-10	0.75	2080700450
2070800350	8.000	3.500	8.50	4.50	3.75	1.50	1.03	8-1/4"-10	0.75	2080800350
2070800400	8.000	4.000	8.50	4.50	3.75	1.50	1.03	8-1/4"-10	0.75	2080800400
2070800450	8.000	4.500	8.50	4.50	3.75	1.50	1.03	8-1/4"-10	0.75	2080800450
2070800500	8.000	5.000	8.50	4.50	3.75	1.50	1.03	8-1/4"-10	0.75	2080800500
2071000400	10.00	4.00	10.50	5.00	4.25	1.50	1.25	10-1/4"-10	1.00	2081000400
2071000500	10.00	5.00	10.50	5.00	4.25	1.50	1.25	10-1/4"-10	1.00	2081000500

IT/ITW Case Thread Technical Information

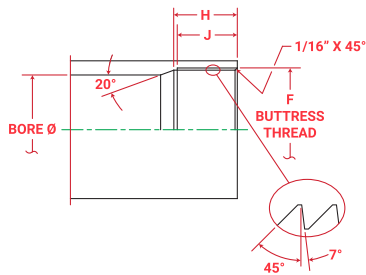

"F" = Buttress Thread as Determined by Head Selection
 "H" = Length of Thread on Head Plus .125"
 "J" = Length of Thread on Head Plus .062"

Basic Thread Size	Minimum Major Diameter	Pitch Diameter	Minor Diameter
2-1/4"-12	2.2604	2.2000 / 2.2075	2.1500 / 2.1575
2-3/4"-12	2.7604	2.7000 / 2.7080	2.6500 / 2.6580
3-1/4"-12	3.2604	3.2000 / 3.2080	3.1500 / 3.1580
3-1/2"-12	3.5104	3.4500 / 3.4580	3.4000 / 3.4080
3-3/4"-12	3.7604	3.7000 / 3.7080	3.6500 / 3.6580
4-1/4"-12	4.2604	4.2000 / 4.2084	4.1500 / 4.1584
4-3/4"-12	4.7604	4.7000 / 4.7084	4.6500 / 4.6584
5-1/4"-12	5.2604	5.2000 / 5.2084	5.1500 / 5.1584
5-3/4"-12	5.7604	5.7000 / 5.7084	5.6500 / 5.6584
6-1/4"-12	6.2604	6.2000 / 6.2084	6.1500 / 6.1584
7-1/4"-10	7.2626	7.1900 / 7.1995	7.1300 / 7.1395
8-1/4"-10	8.2626	8.1900 / 8.1995	8.1300 / 8.1395
10-1/4"-10	10.2626	10.1900 / 10.1995	10.1300 / 10.1395



DOMESTICALLY SOURCED MATERIALS

WORK WITH A DEPENDABLE AMERICAN MANUFACTURER

All of our materials are domestically sourced and every phase of the manufacturing process is controlled internally. Rely on us to provide you with hydraulic cylinder solutions.

Proudly Manufactured in America:

- Know what you're getting and when
- Domestically sourced materials
- Responsive on new designs
- Experts to speak with
- Keep your business running



INTERNALLY THREADED HEAD – HIGH PRESSURE – ITWHP

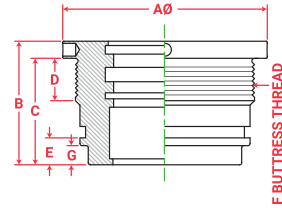

- Material: 65-45-12 ductile iron • Threads into Case (Barrel, Body, Main)
- Buttress Thread design • Pressures up to 5000 PSI with properly designed Case
- Includes Buffer Seal and U-cup Seal Groove
- Standard D-Style or Umbrella Wiper Compatible

Part Number	Bore $\pm .003$ " -.003"	Rod $\pm .000$ " -.003"	A	B	C	D	E	Buttress F	G	Seal Kit
4070300175	3.00	1.75	3.50	2.63	2.25	1.00	0.47	3-1/4"-12	0.31	4080300175U
4070300200	3.00	2.00	3.50	2.63	2.25	1.00	0.47	3-1/4"-12	0.31	4080300200U
4070350175	3.50	1.75	4.00	2.63	2.25	1.00	0.47	3-3/4"-12	0.31	4080350175U
4070350200	3.50	2.00	4.00	2.63	2.25	1.00	0.47	3-3/4"-12	0.31	4080350200U
4070400200	4.00	2.00	4.63	3.25	2.75	1.25	0.53	4-1/4"-12	0.38	4080400200U
4070400250	4.00	2.50	4.63	3.25	2.75	1.25	0.53	4-1/4"-12	0.38	4080400250U
4070400300	4.00	3.00	4.63	3.25	2.75	1.38	0.21	4-1/4"-12	N/A	4080400300U
4070450250	4.50	2.50	5.13	3.25	2.75	1.25	0.53	4-3/4"-12	0.38	4080450250U
4070450300	4.50	3.00	5.13	3.25	2.75	1.25	0.53	4-3/4"-12	0.38	4080450300U
4070450350	4.50	3.50	5.13	3.25	2.75	1.38	0.19	4-3/4"-12	N/A	4080450350U
4070500250	5.00	2.50	5.75	3.63	3.13	1.38	0.78	5-1/4"-12	0.56	4080500250U
4070500300	5.00	3.00	5.75	3.63	3.13	1.38	0.78	5-1/4"-12	0.56	4080500300U
4070500350	5.00	3.50	5.75	3.63	3.13	1.38	0.78	5-1/4"-12	0.56	4080500350U
4070500400	5.00	4.00	5.75	3.63	3.13	1.38	0.19	5-1/4"-12	N/A	4080500400U
4070600300	6.00	3.00	6.75	3.63	3.13	1.38	0.78	6-1/4"-12	0.56	4080600300U
4070600350	6.00	3.50	6.75	3.63	3.13	1.38	0.78	6-1/4"-12	0.56	4080600350U
4070600400	6.00	4.00	6.75	3.63	3.13	1.38	0.78	6-1/4"-12	0.56	4080600400U
4070600450	6.00	4.50	6.75	3.63	3.13	1.38	0.78	6-1/4"-12	0.56	4080600450U

ITWHP Case Thread Technical Information

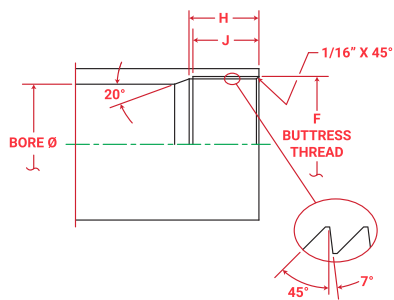

"F" = Buttress Thread as Determined by Head Selection
 "H" = Length of Thread on Head Plus .125"
 "J" = Length of Thread on Head Plus .062"

Basic Thread Size	Minimum Major Diameter	Pitch Diameter	Minor Diameter
3-1/4"-12	3.2604	3.2000 / 3.2080	3.1500 / 3.1580
3-3/4"-12	3.7604	3.7000 / 3.7080	3.6500 / 3.6580
4-1/4"-12	4.2604	4.2000 / 4.2084	4.1500 / 4.1584
4-3/4"-12	4.7604	4.7000 / 4.7084	4.6500 / 4.6584
5-1/4"-12	5.2604	5.2000 / 5.2084	5.1500 / 5.1584
6-1/4"-12	6.2604	6.2000 / 6.2084	6.1500 / 6.1584

TH PISTON

- Material: 65-45-12 ductile iron
- Dual grooves for two symmetrical unloaded u-seals
- Attaches to machined rod stub with lock nut or bolt

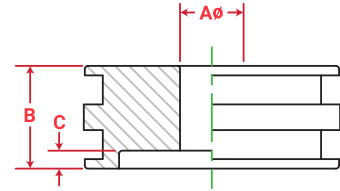
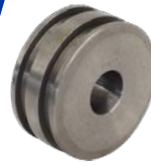

Part Number	Bore +.003" -.003"	A +.002" -.000"	B	C	Seal Kit Number
P70020	1.500	0.626	1.12	N/A	SKP70020
P70005	2.000	0.751	1.50	N/A	SKP70005
P70017	2.500	0.751	1.50	N/A	SKP70017
P70006	3.000	1.001	1.75	N/A	SKP70006
P70007	3.500	1.126	1.75	N/A	SKP70007
P70010	4.000	1.251	1.75	N/A	SKP70010
P70275	4.500	1.251	1.75	N/A	SKP70275
P70018	5.000	1.251	2.00	N/A	SKP70018
P70141	5.500	1.501	2.00	N/A	SKP70141
P70019	6.000	1.501	2.00	N/A	SKP70019
P70175	7.000	1.751	3.00	0.75	SKP70175
P70134	8.000	2.001	3.00	0.75	SKP70134

TM PISTON

- Material: 65-45-12 ductile iron
- Groove for one o-ring and two back up rings
- Attaches to machined rod stub with lock nut or bolt

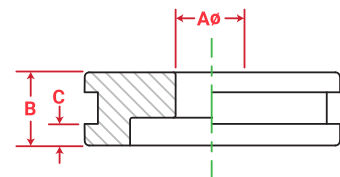

Part Number	Bore +.003" -.003"	A +.002" -.000"	B	C	Seal Kit Number
P70079	1.500	0.626	0.88	N/A	SKP70079
P70055	2.000	0.751	1.00	N/A	SKP70055
P70065	2.500	0.751	1.00	N/A	SKP70065
P70841	3.000	0.751	1.00	0.25	SKP70841
P70872	3.500	1.001	1.00	0.38	SKP70872
P70067	4.000	1.001	1.00	N/A	SKP70067
P70384	4.500	1.251	1.50	N/A	SKP70384
P70090	5.000	1.251	1.50	N/A	SKP70090
P70385	5.500	1.501	1.50	N/A	SKP70385
P70139	6.000	1.501	1.50	N/A	SKP70139

PISTON – NARROW – IT

- Material: 65-45-12 ductile iron
- Grooves for single bidirectional piston seal and single wear ring (guide bearing)
- Attaches to machined rod stub with lock nut or bolt

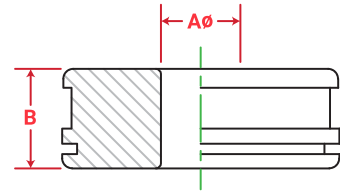

Part Number	Bore +.003" -.003"	A +.002" -.000"	B	Seal Kit Number
1100150062	1.500	0.626	1.12	1180150000
1100175062	1.750	0.626	1.12	1180175000
1100200075	2.000	0.751	1.25	1180200000
1100250075	2.500	0.751	1.25	1180250000
1100300088	3.000	0.876	1.25	1180300000
1100325100	3.250	1.001	1.25	1180325000
1100350100	3.500	1.001	1.25	1180350000
1100400100	4.000	1.001	1.25	1180400000
1100450112	4.500	1.126	1.50	1180450000
1100500112	5.000	1.126	1.50	1180500000

PISTON – WIDE – ITW

- Material: 65-45-12 ductile iron
- Grooves for single bidirectional piston seal and single wear ring (guide bearing)
- Attaches to machined rod stub with lock nut or bolt

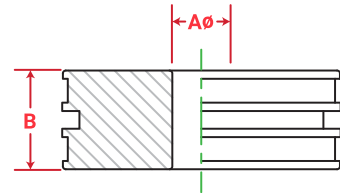

Part Number	Bore +.003" -.003"	A +.002" -.000"	B	Seal Kit Number
2100200062	2.000	0.627	2.00	2180200000
2100200100	2.000	1.001	2.00	2180200000
2100250075	2.500	0.751	1.88	2180250000
2100300100	3.000	1.001	2.00	2180300000
2100325100	3.250	1.001	2.00	2180325000
2100350112	3.500	1.126	2.00	2180350000
2100400112	4.000	1.126	2.00	2180400000
2100450125	4.500	1.251	2.00	2180450000
2100500125	5.000	1.251	2.00	2180500000
2100550125	5.500	1.251	2.12	2180550000
2100600125	6.000	1.251	2.12	2180600000
2100700175	7.000	1.751	2.12	2180700000
2100800200	8.000	2.001	3.12	2180800000
2101000250	10.000	2.501	4.38	2181000000

IMPORTANT INFORMATION:

The stub diameter "A" on pistons supplied by Aggressive Hydraulics are sized to a minimum diameter typically found in low pressure, light duty applications. Medium to heavy duty applications will require the stub diameter to be increased commensurate with the application. Please consult the factory with any questions.

BASE PLATE END CAP – MEDIUM-DUTY

• Material: A-36 or 1018 steel

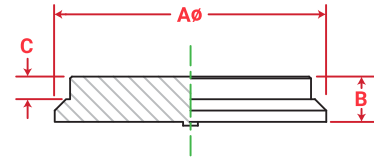

Part Number	Bore $\pm .003"$ $-.003"$	A	B	C
BP60056	1.500	1.88	0.50	0.25
BP60010	2.000	2.38	0.50	0.25
BP60011	2.500	2.88	0.50	0.25
BP60012	3.000	3.38	0.59	0.25
BP60013	3.500	3.88	0.69	0.38
BP60014	4.000	4.50	0.75	0.38
BP60437	4.500	5.00	0.88	0.38
BP60015	5.000	5.56	0.88	0.38
BP60124	5.500	6.00	0.88	0.38
BP60016	6.000	6.75	1.00	0.38
BP60157	7.000	8.00	1.00	0.38
BP60107	8.000	9.00	1.00	0.38

BASE PLATE END CAP – HEAVY-DUTY

• Material: A-36 or 1018 steel

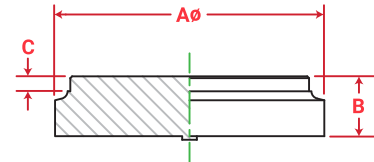

Part Number	Bore $\pm .003"$ $-.003"$	A	B	C
1120150050	1.500	2.00	0.50	0.19
1120175050	1.750	2.25	0.50	0.12
1120200050	2.000	2.50	0.50	0.12
1120225062	2.250	2.75	0.62	0.25
1120250062	2.500	3.00	0.62	0.25
1120300075	3.000	3.50	0.75	0.25
1120325088	3.250	3.75	0.88	0.25
1120350062	3.500	4.00	0.62	0.25
1120350088	3.500	4.00	0.88	0.25
1120400075	4.000	4.50	0.75	0.25
1120400100	4.000	4.50	1.00	0.25
1120450112	4.500	5.00	1.12	0.25
1120500125	5.000	5.75	1.25	0.25
1120550131	5.500	6.12	1.31	0.25
1120600138	6.000	6.75	1.38	0.25
1120700144	7.000	8.00	1.44	0.25
1120800150	8.000	9.00	1.50	0.25
1121000150	10.000	11.00	1.50	0.38

CROSS TUBE

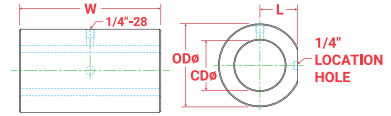
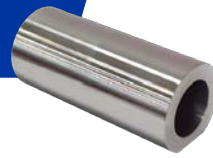

- Material: 1026 CDS (cold drawn seamless mechanical tubing)
- Drilled & tapped for 1/4"-28 zerk (grease) fitting
- Drilled with 1/4" mounting location hole

Part Number	CD	W	OD	L	Part Number	CD	W	OD	L
1230150712	0.75	1.50	1.25	0.56	1230601220	1.25	6.00	2.00	0.88
1230200712	0.75	2.00	1.25	0.56	1230701220	1.25	7.00	2.00	0.88
1230250712	0.75	2.50	1.25	0.56	1230301525	1.50	3.00	2.50	1.12
1230300712	0.75	3.00	1.25	0.56	1230401525	1.50	4.00	2.50	1.12
1230350712	0.75	3.50	1.25	0.56	1230421525	1.50	4.25	2.50	1.12
1230251015	1.00	2.50	1.50	0.69	1230471525	1.50	4.75	2.50	1.12
1230301015	1.00	3.00	1.50	0.69	1230551525	1.50	5.50	2.50	1.12
1230351015	1.00	3.50	1.50	0.69	1230601525	1.50	6.00	2.50	1.12
1230401015	1.00	4.00	1.50	0.69	1230671525	1.50	6.75	2.50	1.12
1230451015	1.00	4.50	1.50	0.69	1230701525	1.50	7.00	2.50	1.12
1230271017	1.00	2.75	1.75	0.81	1230321727	1.75	3.25	2.75	1.25
1230321017	1.00	3.25	1.75	0.81	1230471727	1.75	4.75	2.75	1.25
1230371017	1.00	3.75	1.75	0.81	1230551727	1.75	5.50	2.75	1.25
1230421017	1.00	4.25	1.75	0.81	1230601727	1.75	6.00	2.75	1.25
1230471017	1.00	4.75	1.75	0.81	1230701727	1.75	7.00	2.75	1.25
1230521017	1.00	5.25	1.75	0.81	1230352030	2.00	3.50	3.00	1.38
1230271220	1.25	2.75	2.00	0.88	1230402030	2.00	4.00	3.00	1.38
1230301220	1.25	3.00	2.00	0.88	1230472030	2.00	4.75	3.00	1.38
1230321220	1.25	3.25	2.00	0.88	1230502030	2.00	5.00	3.00	1.38
1230371220	1.25	3.75	2.00	0.88	1230552030	2.00	5.50	3.00	1.38
1230421220	1.25	4.25	2.00	0.88	1230602030	2.00	6.00	3.00	1.38
1230451220	1.25	4.50	2.00	0.88	1230702030	2.00	7.00	3.00	1.38
1230471220	1.25	4.75	2.00	0.88	1230802030	2.00	8.00	3.00	1.38
1230521220	1.25	5.25	2.00	0.88					

SPHERICAL TANG – ROD END

- Material: 50 ksi min. yield steel plate
- Drilled & tapped for 1/4"-28 zerk (grease) fitting
- Drilled with 1/4" mounting location hole

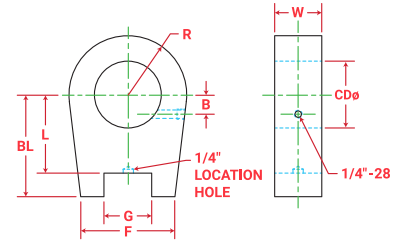

Part Number	CD	L	R	BL	W	B	F	G	Nominal Bearing Hole Diameter	Spherical Bearing	Max. Pull #
1212075100	1.625	2.12	1.25	2.75	0.75	0.50	2.00	1.015	1.00	9995000100	13,033
1212093125	2.000	2.25	1.50	3.00	0.93	0.50	2.25	1.265	1.25	9995000125	18,555
1212112150	2.437	2.50	1.88	3.25	1.12	0.63	3.00	1.515	1.50	9995000150	29,158
1212131175	2.812	2.75	2.00	3.75	1.31	0.88	3.00	1.515	1.75	9995000175	31,146
1212150200	3.188	3.00	2.38	4.00	1.50	0.88	3.50	2.015	2.00	9995000200	46,829
1212188250	3.937	3.50	3.00	4.75	1.88	1.25	4.50	2.515	2.50	9995000250	76,871

SPHERICAL TANG – BASE END

- Material: 50 ksi min. yield steel plate
- Drilled & tapped for 1/4"-28 zerk (grease) fitting

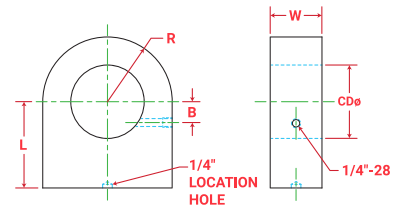

Part Number	CD	L	R	W	B	Nominal Bearing Hole Diameter	Spherical Bearing	Max. Pull #
1211075100	1.625	2.00	1.25	0.75	0.50	1.00	9995000100	13,033
1211093125	2.000	2.00	1.50	0.93	0.50	1.25	9995000125	18,555
1211112150	2.437	2.50	1.88	1.12	0.63	1.50	9995000150	29,158
1211131175	2.812	2.50	2.00	1.31	0.88	1.75	9995000175	31,146
1211150200	3.188	2.75	2.38	1.50	0.88	2.00	9995000200	46,829
1211188250	3.937	3.25	3.00	1.88	1.25	2.50	9995000250	76,871

SPHERICAL TANG SNAP RING – ROD END

- Material: 50 ksi min. yield plate
- Drilled & tapped for 1/4"-28 zerk (grease) fitting
- Drilled with 1/4" mounting location hole
- Mount machined for snap ring to retain spherical bearing

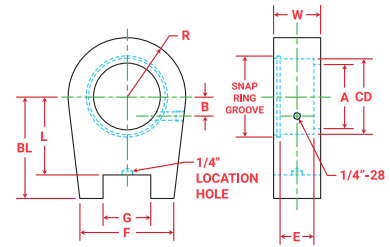

Part Number	CD	L	R	BL	W	A	B	E	F	G	Dia. Pin	Spherical Bearing	Retaining Ring	Max. Pull #
1212112100	1.625	2.13	1.25	2.75	1.13	1.38	0.50	0.75	2.00	1.02	1.00	9995000100	N5000-162	13,033
1212125125	2.000	2.25	1.50	3.00	1.25	1.75	0.50	0.94	2.25	1.27	1.25	9995000125	N5000-200	18,555
1212150150	2.437	2.50	1.88	3.25	1.50	2.13	0.63	1.13	3.00	1.52	1.50	9995000150	N5000-244	29,158
1212175175	2.812	2.75	2.00	3.75	1.75	2.50	0.88	1.31	3.00	1.52	1.75	9995000175	N5000-281	31,146
1212200200	3.187	3.00	2.38	4.00	2.00	2.75	0.88	1.50	3.50	2.02	2.00	9995000200	N5000-315	46,829
1212225250	3.937	3.50	3.00	4.75	2.25	3.50	1.25	1.88	4.50	2.52	2.50	9995000250	N5000-393	76,871

SPHERICAL TANG SNAP RING – BASE END

- Material: 50 ksi min. yield plate
- Drilled & tapped for 1/4"-28 zerk (grease) fitting
- Drilled with 1/4" mounting location hole
- Mount machined for snap ring to retain spherical bearing

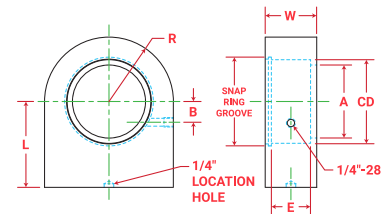

Part Number	CD	L	R	W	A	B	E	Pin Dia.	Spherical Bearing	Retaining Ring	Max. Pull #
1211112100	1.625	2.00	1.25	1.13	1.38	0.50	0.75	1.00	9995000100	N5000-162	13,033
1211125125	2.000	2.00	1.50	1.25	1.75	0.50	0.94	1.25	9995000125	N5000-200	18,555
1211150150	2.437	2.50	1.88	1.50	2.13	0.63	1.13	1.50	9995000150	N5000-244	29,158
1211175175	2.812	2.50	2.00	1.75	2.50	0.88	1.31	1.75	9995000175	N5000-281	31,146
1211200200	3.187	2.75	2.38	2.00	2.75	0.88	1.50	2.00	9995000200	N5000-315	46,829
1211225250	3.937	3.25	3.00	2.25	3.50	1.25	1.88	2.50	9995000250	N5000-393	76,871

LUG MOUNT – BURNING

- Material: A-36 steel plate
- NO hole; drill / bore pin Mounting hole as required
- Welds onto base or rod ends

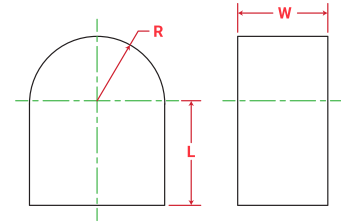

Part Number	L	R	W
ML296	1.50	1.00	0.50
ML297	1.50	1.00	0.62
ML298	1.50	1.00	0.75
ML303	1.50	1.00	1.25
ML304	1.50	1.12	1.50
ML306	1.75	1.50	1.50
ML299	1.75	1.25	1.00
ML313	1.75	1.75	2.00
ML308	1.75	1.25	2.00
ML314	1.88	1.75	2.00
ML301	2.00	1.50	1.00
ML305	2.00	1.25	1.50
ML309	2.00	1.50	2.00
ML321	2.00	1.12	2.25
ML310	2.12	1.50	2.00

Part Number	L	R	W
ML315	2.12	1.75	2.00
ML311	2.25	1.50	2.00
ML322	2.25	1.75	2.25
ML316	2.50	1.75	2.00
ML302	2.50	2.00	1.00
ML307	2.75	1.50	1.50
ML317	2.75	1.75	2.00
ML318	3.00	2.00	2.00
ML319	3.00	2.12	2.00
ML323	3.00	2.50	2.25
ML324	3.00	2.50	2.50
ML325	3.00	2.25	3.00
ML326	3.00	2.00	3.25
ML312	3.00	1.50	2.00
ML320	3.12	2.50	2.00

FORMED CLEVIS

- Material: A-36 plate
- Welds onto base or rod ends
- Parts with CD of "N/A" are provided with no hole for customer to drill/bore mounting hole as required

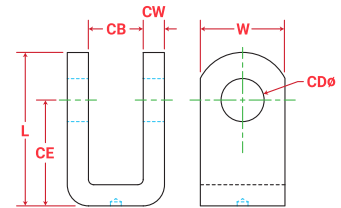

Part Number	CB	CD	CE	CW	L	W
80003	0.50	N/A	N/A	0.38	2.38	1.00
CL3011	0.75	0.50	1.50	0.38	2.25	1.25
CL8278	0.88	1.00	2.93	0.50	4.06	2.00
CL7337	1.06	0.75	2.00	0.38	3.12	1.75
80010	1.12	N/A	N/A	0.38	3.50	2.00
B120760	1.12	1.00	2.12	0.62	3.38	2.50
B120756	1.12	N/A	N/A	0.62	4.25	3.00
80001	1.12	N/A	N/A	0.50	4.00	2.00
80015	1.25	N/A	N/A	0.62	4.62	2.50

Part Number	CB	CD	CE	CW	L	W
CL6547	1.25	1.00	2.50	0.50	3.62	2.00
CL323	1.25	1.00	5.06	0.38	6.06	1.75
B120753	1.50	1.12	2.12	0.50	3.25	2.25
B120829	1.50	N/A	N/A	0.50	3.25	2.50
B120672	1.50	N/A	N/A	0.50	4.00	3.00
B1201078	1.50	N/A	N/A	0.62	4.12	3.00
B120613	1.62	N/A	N/A	0.75	4.00	2.50
B120625	1.62	1.25	2.75	0.75	4.00	2.50
B120614	2.12	N/A	N/A	1.00	5.00	3.00

LUG MOUNT – MACHINED

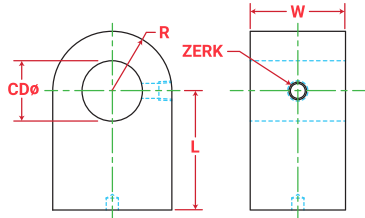

- Material: A-36 steel plate
- Mounting hole pre-machined
- Welds onto base or rod ends
- Parts with N/A for zerk are not drilled and tapped for a grease zerk

Part Number	CD	L	R	W	Zerk
1210050100	1.00	2.00	1.00	0.50	N/A
1210062100	1.00	2.00	1.00	0.62	N/A
1210075100	1.00	2.12	1.00	0.75	N/A
1210100100	1.00	2.00	1.00	1.00	N/A
1210125100	1.00	2.00	1.00	1.25	1/8" NPT
1210062125	1.25	2.50	1.25	0.62	N/A
1210075125	1.25	2.50	1.25	0.75	N/A
1210100125	1.25	2.50	1.25	1.00	N/A
1210150125	1.25	2.50	1.25	1.50	1/8" NPT
1210200125	1.25	2.50	1.25	2.00	1/8" NPT
1210062150	1.50	2.50	1.50	0.62	N/A
1210075150	1.50	2.50	1.50	0.75	N/A
1210150150	1.50	2.50	1.50	1.50	1/8" NPT
1210200150	1.50	2.50	1.50	2.00	1/8" NPT
1210250150	1.50	2.50	1.50	2.50	1/8" NPT
1210125200	2.00	2.50	2.00	1.25	N/A
1210200200	2.00	3.00	2.00	2.00	1/8" NPT
1210250200	2.00	3.00	2.00	2.50	1/8" NPT

THREADED ROD EYE

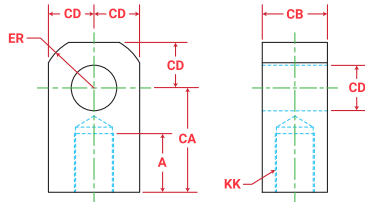

- Material: 05 through 20 are 1117 steel; 25 through 40 are 11L7 steel
- Threads onto rod end

Part Number	A	CA	CB	CD	ER	KK
BDE-05	0.75	1.50	0.75	0.50	0.63	7/16"-20
BDE-07	1.13	2.06	1.25	0.75	0.88	3/4"-16
BDE-10	1.63	2.81	1.50	1.00	1.18	1"-14
BDE-13	2.00	3.44	2.00	1.37	1.56	1-1/4"-12
BDE-17	2.25	4.00	2.50	1.75	2.00	1-1/2"-12
BDE-20	3.00	5.00	2.50	2.00	2.50	1-7/8"-12
BDE-25	3.50	5.81	3.00	2.50	2.81	2-1/4"-12
BDE-30	3.50	6.13	3.00	3.00	3.25	2-1/2"-12
BDE-35	4.50	7.63	4.00	3.50	3.88	3-1/4"-12
BDE-40	5.50	9.13	4.50	4.00	4.44	4"-12

EYE BRACKET – SINGLE LUG

- Material: 05, 07, and 10 are 1144 steel forging; 13 and up are ductile iron casting
- Drilled for mounting bolts
- Note: eye brackets are not weldable

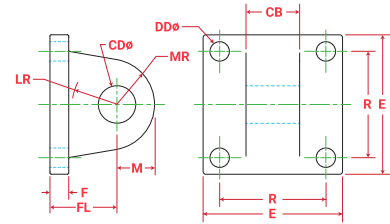

Part Number	CB	CD	DD	E	F	FL	LR	M	MR	R
BDEB-05	0.75	0.50	0.41	2.50	0.38	1.13	0.75	0.50	0.56	1.63
BDEB-07	1.25	0.75	0.53	3.50	0.63	1.88	1.25	0.75	0.88	2.56
BDEB-10	1.50	1.00	0.66	4.50	0.75	2.25	1.50	1.00	1.25	3.25
BDEB-13	2.00	1.37	0.66	5.00	0.88	3.00	2.13	1.38	1.63	3.81
BDEB-17	2.50	1.75	0.91	6.50	0.88	3.13	2.25	1.75	2.13	4.95
BDEB-20	2.50	2.00	1.06	7.50	1.00	3.50	2.50	2.00	2.44	5.75
BDEB-25	3.00	2.50	1.19	8.50	1.00	4.00	3.00	2.50	3.00	6.59
BDEB-30	3.00	3.00	1.31	9.50	1.00	4.25	3.25	3.00	3.25	7.50
BDEB-35	4.00	3.50	1.81	12.63	1.69	5.69	4.00	3.50	4.13	9.62
BDEB-40	4.50	4.00	2.06	14.88	1.94	6.44	4.50	4.00	5.25	11.50

SPHERICAL EYE BRACKET

- Material: 05, 07, and 10 are 1144 steel forging; 13 and up are ductile iron casting
- Drilled for 4 mounting bolts
- Includes spherical (self-aligning) bearing
- Note: eye brackets are not weldable

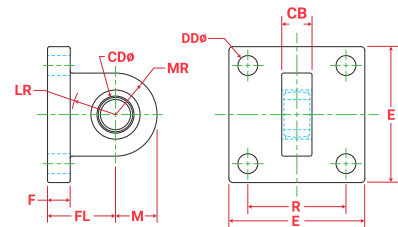
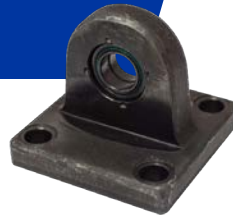

Part Number	CB	CD +.0000 -.0005	DD	E	F	FL	LR	M	MR	R
BDS-05	0.50	0.5000	0.41	2.50	0.38	1.13	0.75	0.69	0.69	1.62
BDS-07	0.75	0.7500	0.53	3.50	0.63	1.88	1.25	1.19	1.19	2.56
BDS-10	1.00	1.0000	0.66	4.50	0.75	2.25	1.50	1.38	1.38	3.25
BDS-13	1.38	1.3750	0.66	5.00	0.88	3.00	2.13	2.00	2.00	3.81
BDS-17	1.50	1.7500	0.91	6.50	0.88	3.13	2.25	2.13	2.13	4.94
BDS-20	1.75	2.0000	1.03	7.50	1.00	3.50	2.50	2.38	2.38	5.75

SPHERICAL ROD EYE

- Material: ductile iron casting
- Includes grease zerk and spherical bearing

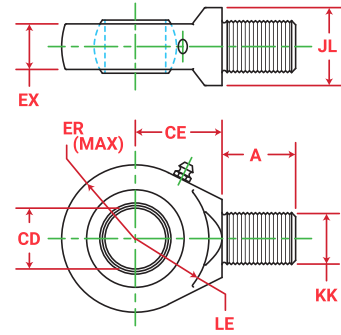

Part Number	CD +.0000" -.0005"	A	CE	EX	ER	LE	KK	JL (REF.)	Max. Pull #
RES-05	0.5000	0.69	0.88	0.44	0.88	0.75	7/16"-20	0.88	2,600
RES-07	0.7500	1.00	1.25	0.66	1.25	1.06	3/4"-16	1.31	9,400
RES-10	1.0000	1.50	1.88	0.88	1.38	1.44	1"-14	1.50	16,800
RES-13	1.3750	2.00	2.13	1.19	1.81	1.88	1-1/4"-12	2.00	28,600
RES-17	1.7500	2.13	2.50	1.53	2.19	2.13	1-1/2"-12	2.25	43,000
RES-20	2.0000	2.88	2.75	1.75	2.63	2.50	1-7/8"-12	2.75	70,000

CLEVIS BRACKET – DOUBLE LUGS

- Material: ductile iron casting
- Drilled & tapped for 4 mounting bolts
- Note: clevis brackets are not weldable

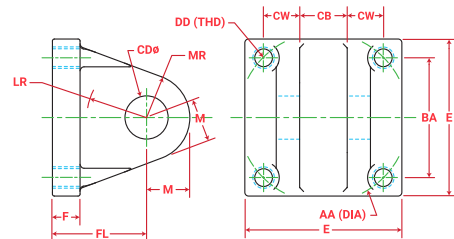

Part Number	AA	BA	CB	CD	CW	DD	E	F	FL	LR	M	MR
BDCB-05	2.3	1.63	0.765	0.503	0.50	3/8"-24	2.5	0.38	1.13	0.50	0.50	0.56
BDCB-06	2.9	2.06	1.265	.753	0.63	1/2"-20	3.0	0.63	1.88	1.00	0.75	1.06
BDCB-07	3.6	2.56	1.265	.753	0.63	1/2"-20	3.5	0.63	1.88	1.06	0.75	1.06
BDCB-10	4.6	3.25	1.515	1.003	0.75	5/8"-18	4.5	0.75	2.25	1.25	1.00	1.13
BDCB-13	5.4	3.81	2.032	1.378	1.00	5/8"-18	5.0	0.88	3.00	1.88	1.38	1.75
BDCB-17	7.0	4.94	2.531	1.753	1.25	7/8"-14	6.5	0.88	3.13	2.00	1.75	1.88

THREADED ROD CLEVIS

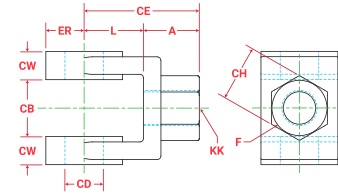

- Material: 05, 07, 10 are forged Steel, 13 & up are cast ductile iron
- Threads onto rod end

Part Number	CB	CD	CE	CH	CW	F	L	A	KK	ER
BDC-05	0.765	0.503	1.50	1.00	0.50	1.00	0.75	0.75	7/16"-20	0.50
BDC-07	1.265	0.753	2.38	1.25	0.62	1.25	1.25	1.13	3/4"-16	0.75
BDC-10	1.515	1.003	3.13	1.50	0.75	1.50	1.50	1.63	1"-14	1.00
BDC-13	2.032	1.378	4.13	2.00	1.00	2.00	2.13	2.00	1-1/4"-12	1.38
BDC-17	2.531	1.753	4.50	2.38	1.25	2.38	2.25	2.25	1-1/2"-12	1.75
BDC-20	2.531	2.003	5.50	2.94	1.25	2.94	2.50	3.00	1-7/8"-12	2.00
BDC-25	3.032	2.503	6.50	3.50	1.50	3.50	3.00	3.50	2-1/4"-12	2.50
BDC-30	3.032	3.003	6.75	3.88	1.50	3.88	3.25	3.50	2-1/2"-12	2.75
BDC-35	4.032	3.503	8.50	5.00	2.00	5.00	4.00	4.50	3-1/4"-12	3.50
BDC-40	4.532	4.003	10.00	6.13	2.25	6.13	4.50	5.50	4"-12	4.00

ALIGNMENT COUPLER

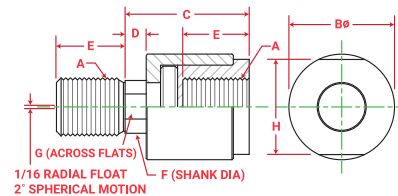

- 1/16 radial float 2° • Threaded design
- High tensile, hardened & blackened steel
- Alignment couplers are designed to simplify alignment issues, resist vibrational loosening, and allow excellent freedom of movement

Part Number	A	B	C	D	E	F	G	H	Max. Pull #
BD-250F	1/4"-28	0.88	1.25	0.25	0.63	0.245	0.19	0.81	4,000
BD-312F	5/16"-24	0.88	1.25	0.25	0.63	0.308	0.25	0.81	4,000
BD-375C	3/8"-16	0.88	1.25	0.25	0.63	0.369	0.31	0.81	5,000
BD-375F	3/8"-24	0.88	1.25	0.25	0.63	0.370	0.31	0.81	5,000
BD-437F	7/16"-20	1.25	2.00	0.50	0.75	0.625	0.31	1.13	10,000
BD-500C	1/2"-13	1.25	2.00	0.50	0.75	0.625	0.56	1.13	14,000
BD-500F	1/2"-20	1.25	2.00	0.50	0.75	0.625	0.56	1.13	14,000
BD-625F	5/8"-18	1.25	2.00	0.50	0.75	0.625	0.50	1.13	14,000
BD-750C	3/4"-10	1.75	2.31	0.31	1.13	0.969	0.88	1.50	34,000
BD-750F	3/4"-16	1.75	2.31	0.31	1.13	0.969	0.88	1.50	34,000
BD-875F	7/8"-14	1.75	2.31	0.31	1.13	0.969	0.88	1.50	34,000
BD-1000C	1"-8	2.50	2.94	0.50	1.63	1.375	1.25	2.25	64,000
BD-1000F	1"-14	2.50	2.94	0.50	1.63	1.375	1.25	2.25	64,000
BD-1250F	1-1/4"-12	2.50	2.94	0.50	1.63	1.375	1.25	2.25	64,000
BD-1375F	1-3/8"-12	2.50	2.94	0.50	1.63	1.375	1.25	2.25	64,000
BD-1500F	1-1/2"-12	3.25	4.38	0.81	2.25	1.750	1.50	3.00	120,000
BD-1750F	1-3/4"-12	3.25	4.38	0.81	2.25	1.750	1.50	3.00	120,000
BD-1875F	1-7/8"-12	3.75	5.44	0.69	3.00	2.250	1.88	3.50	240,000
BD-2000F	2"-12	3.75	5.44	0.69	3.00	2.250	1.88	3.50	240,000

PIVOT PIN – DRILLED

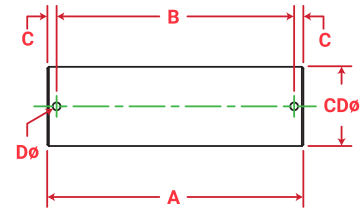

- Material: 1144 steel
- Drilled thru both ends for cotter pins
- Nitrotec treated surface

Part Number	CD	A	B	C	D
BDP-05H	0.500	2.281	1.938	0.172	0.106
BDP-07H	0.750	3.094	2.719	0.188	0.140
BDP-10H	1.000	3.594	3.219	0.188	0.140
BDP-13H	1.375	4.656	4.250	0.203	0.173
BDP-17H	1.750	5.656	5.250	0.203	0.173
BDP-20H	2.000	5.719	5.281	0.219	0.204
BDP-25H	2.500	6.781	6.313	0.234	0.219
BPD-30H	3.000	6.844	6.344	0.250	0.250
BDP-35H	3.500	8.969	8.406	0.282	0.312
BDP-40H	4.000	9.969	9.406	0.282	0.312

PIVOT PIN – GROOVED

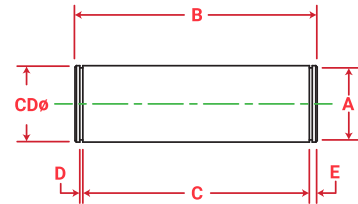

- Material: 1144 steel
- Both ends machined to accept retainer rings
- Nitrotec treated surface

Part Number	CD	A	B	C	D	E
BDP-05G	0.500	0.468	2.094	1.875	0.041	0.109
BDP-07G	0.750	0.704	2.875	2.625	0.048	0.125
BDP-10G	1.000	0.940	3.375	3.125	0.048	0.125
BDP-12G	1.250	1.176	3.750	3.500	0.056	0.125
BDP-13G	1.375	1.291	4.485	4.187	0.056	0.149
BDP-15G	1.500	1.406	4.750	4.500	0.056	0.125
BDP-17G	1.750	1.650	5.547	5.188	0.068	0.180
BDP-20G	2.000	1.886	5.547	5.188	0.068	0.180
BDP-25G	2.500	2.360	6.625	6.188	0.086	0.219
BPD-30G	3.000	2.838	6.780	6.250	0.103	0.265
BDP-35G	3.500	3.316	8.845	8.125	0.120	0.360
BDP-40G	4.000	3.792	9.845	9.125	0.120	0.360

MEA MOUNTING EAR

- Material: CD 1018
- NO hole: drill / bore pin mounting hole as required
- Welds onto base or rod ends

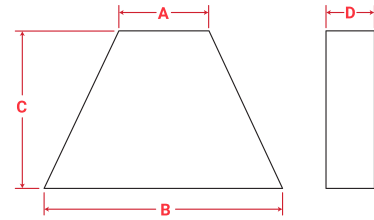
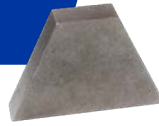

Part Number	A	B	C	D
MEA-100	0.56	1.75	1.25	0.50
MEA-200	0.88	2.75	2.00	0.63
MEA-300	1.38	3.75	2.50	0.75
MEA-400	1.75	5.00	3.50	1.00
MEA-500	1.25	4.00	3.50	1.25
MEA-600	1.25	6.75	4.50	1.25

ME MOUNTING EAR

- Material: CD 1018
- NO hole: drill / bore pin mounting hole as required
- Welds onto base or rod ends

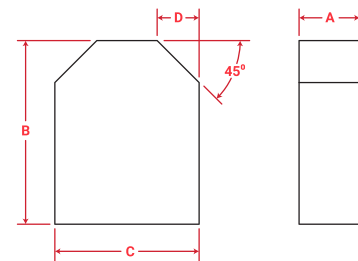

Part Number	A	B	C	D
ME-100	0.50	1.25	1.00	0.29
ME-200	0.63	2.00	1.50	0.44
ME-300	0.75	2.25	2.00	0.58
ME-400	1.00	3.50	2.75	0.80
ME-500	1.25	4.00	3.50	1.02
ME-600	1.25	4.50	4.00	1.17

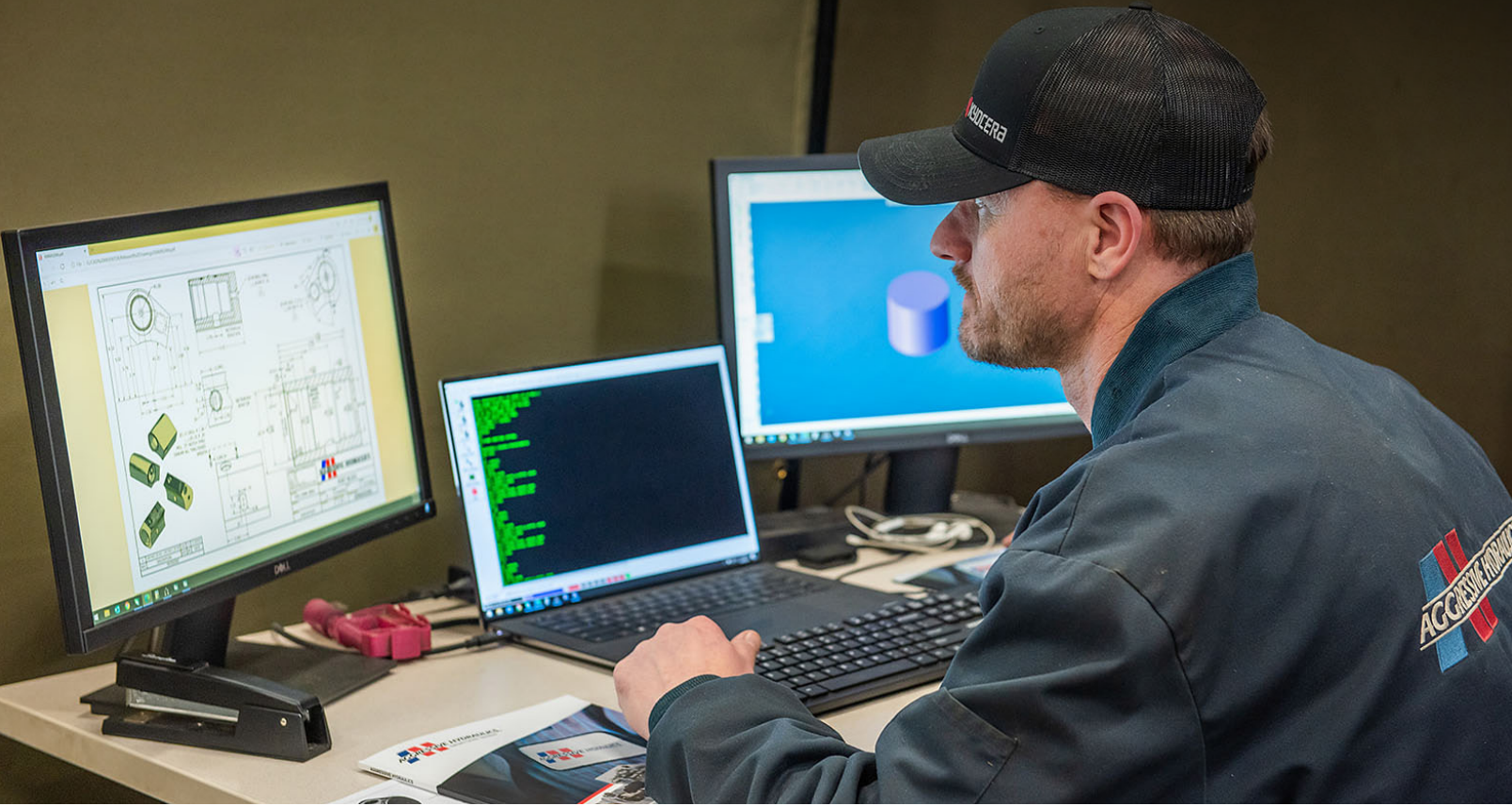

THREADED STUD

• Material: 4140 H.T.

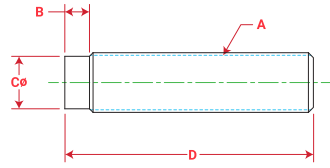

Part Number	A	B	C	D
0121000023	7/16"-20	0.31	0.35	1.62
0121000013	3/4"-16	0.31	0.66	2.50
0121000022	3/4"-16	0.31	0.66	3.12
0121000016	3/4"-16	0.31	0.66	3.62
0121000067	1"-14	0.31	0.91	3.12

Part Number	A	B	C	D
1320000072	1"-14	0.31	0.89	4.00
1320000440	1-1/4"-12	0.31	1.12	3.12
1320000462	1-1/4"-12	0.31	1.12	4.12
1320000310	1-1/4"-12	0.44	1.15	4.38
1320000460	1-1/2"-12	0.31	1.38	4.25

O-RING BOSS HALF COUPLING PORT

- Material: CD 1020
- Weldable

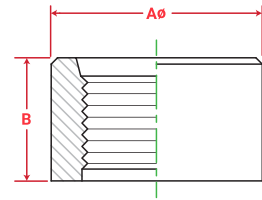

Part Number	Port Size	A	B
6500003004	7/16"-20 SAE #4	0.75	0.62
6500003005	1/2"-20 SAE #5	0.88	0.75
6500003006	9/16"-18 SAE #6	1.00	0.75
6500003008	3/4"-16 SAE #8	1.12	0.88
6500003010	7/8"-14 SAE #10	1.25	0.88
6500003012	1-1/16"-12 SAE #12	1.50	0.88
6500003014	1-3/16"-12 SAE #14	1.75	1.00
6500003016	1-5/16"-12 SAE #16	2.00	1.00
6500003020	1-5/8"-12 SAE #20	2.25	1.00
6500003024	1-7/8"-12 SAE #24	2.50	1.25

90 DEGREE O-RING BOSS PORT

- Material: CD 1020
- Weldable

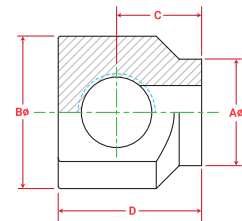

Part Number	Port Size	A	B	C	D
6500006004	7/16"-20 SAE #4	0.75	1.12	0.75	1.12
6500006006	9/16"-18 SAE #6	0.88	1.25	0.81	1.25
6500006008	3/4"-16 SAE #8	1.25	1.62	1.00	1.62
6500006010	7/8"-14 SAE #10	1.25	1.75	1.12	1.88
6500006012	1-1/16"-12 SAE #12	1.50	2.12	1.19	2.00
6500006016	1-5/16"-12 SAE #16	1.50	2.25	1.25	2.38

NPTF HALF COUPLING PORT

- Material: ASTM A105 or CD 1020
- Weldable

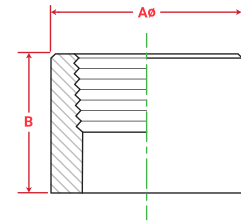

Part Number	Port Size	A	B
6500005012	1/8" NPTF	0.75	0.62
6500005025	1/4" NPTF	0.75	0.69
6500005038	3/8" NPTF	0.88	0.75
6500005050	1/2" NPTF	1.12	0.93
6500005075	3/4" NPTF	1.38	1.00
6500005100	1" NPTF	1.75	1.12
6500005125	1-1/4" NPTF	2.25	1.31
6500005150	1-1/2" NPTF	2.50	1.62

90 DEGREE NPTF PORT

- Material: CD 1020
- Weldable

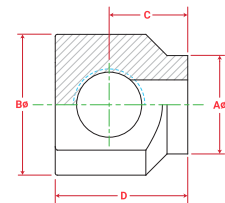

Part Number	Port Size	A	B	C	D
6500009025	1/4" NPTF	0.75	1.13	0.73	1.17
6500009038	3/8" NPTF	0.88	1.25	0.75	1.25
6500009050	1/2" NPTF	1.13	1.75	0.94	1.53
6500009075	3/4" NPTF	1.38	2.25	1.30	2.05
6500009100	1" NPTF	1.63	2.63	1.45	2.32

SINGLE VALVE BLOCK

- Material: 1018 bar
- Single valve cavity
- Prepared for welded fluid lines

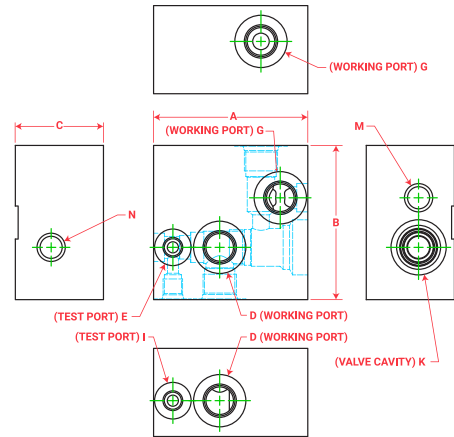

Part Number	A	B	C	D	E	G	H	I	K	M	N
1390000251	3.50	3.50	2.00	#8 ORB	#4 ORB	#8 ORB	#8 ORB	#4 ORB	T-11A Cavity	0.62ø Fluid Line	0.62ø Fluid Line
1390000252	5.00	4.50	2.50	#12 ORB	#6 ORB	#12 ORB	#12 ORB	#6 ORB	T-2A Cavity	0.88ø Fluid Line	0.88ø Fluid Line

DUAL VALVE BLOCK

- Material: CD 1018
- Dual valve cavity
- Prepared for welded fluid lines

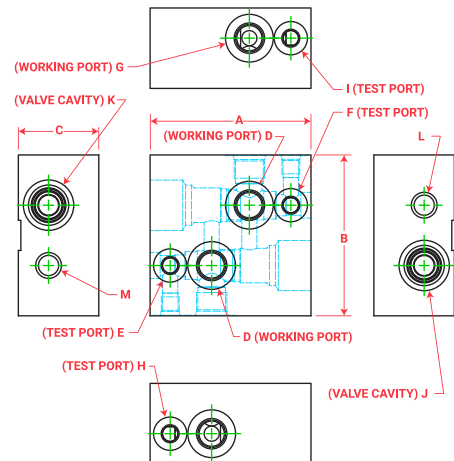

Part Number	A	B	C	D	E	F	G	H	I	J	K	L	M
1390000230	4.00	4.00	2.00	#8 ORB	#4 ORB	#4 ORB	#8 ORB	#4 ORB	#4 ORB	T-11A Cavity	T-11A Cavity	0.62ø Fluid Line	0.62ø Fluid Line
1390000231	5.00	5.50	2.50	#12 ORB	#6 ORB	#6 ORB	#12 ORB	#6 ORB	#6 ORB	T-2A Cavity	T-2A Cavity	0.88ø Fluid Line	0.88ø Fluid Line

FLUID LINE ELBOW

- Material: CD 1018 or 1020
- Welds on body
- Prepared for welded fluid line

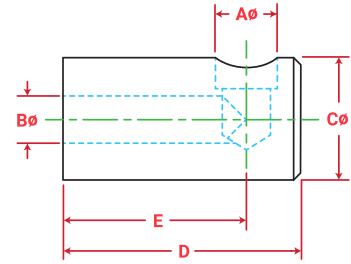

Part Number	A (FL OD)	B	C	D	E
1240000409	0.50	0.38	1.00	1.94	1.50
1240000405	0.62	0.50	1.13	2.00	1.50
1240000406	0.75	0.63	1.25	2.38	1.75
1240000407	0.87	0.63	1.50	2.69	2.00
1240000408	1.00	0.75	1.75	2.75	2.00



STEEL PLUG O-RING BOSS

- Internal hex head design for easy installation

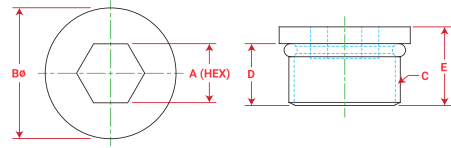

Part Number	A	B	C	D	E
650008004	3/16"	0.56	7/16"-20 SAE #4	0.36	0.46
650008006	1/4"	0.69	9/16"-18 SAE #6	0.40	0.49
650008008	5/16"	0.88	3/4"-16 SAE #8	0.44	0.57
650008010	3/8"	1.00	7/8"-14 SAE #10	0.50	0.63
650008012	9/16"	1.25	1-1/16"-12 SAE #12	0.59	0.75
650008014	9/16"	1.38	1-3/16"-12 SAE #14	0.59	0.75
650008016	5/8"	1.50	1-5/16"-12 SAE #16	0.59	0.75
650008020	3/4"	1.88	1-5/8"-12 SAE #20	0.59	0.75

STEEL PLUG NPTF

- Internal hex head design for easy installation

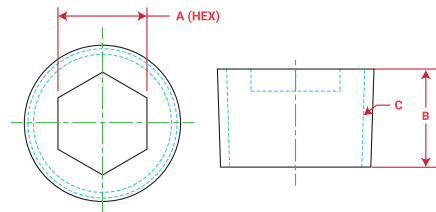

Part Number	A	B	C
650007012	3/16"	0.30	1/8" NPTF
650007025	1/4"	0.46	1/4" NPTF
650007038	5/16"	0.46	3/8" NPTF
650007050	3/8"	0.61	1/2" NPTF
650007075	9/16"	0.62	3/4" NPTF
650007100	5/8"	0.77	1" NPTF
650007125	3/4"	0.81	1-1/4" NPTF

SPLIT TENSION BUSHING

• Material: hardened spring steel

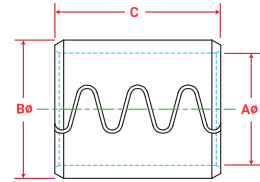

Part Number	A	B	C	Housing Diameter
6500995086	0.75	1.00	0.62	1.006/1.002
650099507	0.75	1.00	2.00	1.006/1.002
650099508	0.88	1.00	2.00	1.006/1.002
650099509	1.00	1.25	0.50	1.256/1.252
650099510	1.00	1.25	0.75	1.256/1.252
650099514	1.00	1.25	0.88	1.256/1.252
650099511	1.00	1.25	1.00	1.256/1.252
650099513	1.00	1.25	1.25	1.256/1.252
650099512	1.00	1.25	1.50	1.256/1.252
6500995186	1.25	1.50	1.00	1.506/1.502
650099519	1.25	1.50	1.25	1.506/1.502
650099522	1.25	1.50	1.50	1.506/1.502
650099521	1.25	1.50	2.00	1.506/1.502
650099525	1.38	1.62	1.00	1.631/1.627
650099531	1.50	1.75	1.50	1.756/1.752
650099533	1.50	1.75	2.00	1.756/1.752
6500995335	1.50	1.75	2.50	1.756/1.752
650099535	1.50	1.75	3.00	1.756/1.752
650099534	1.50	1.88	2.00	1.881/1.877
650099537	1.50	2.00	1.25	2.006/2.002
6500995371	1.50	2.00	2.00	2.006/2.002

Part Number	A	B	C	Housing Diameter
650099540	1.75	2.00	1.25	2.006/2.002
6500995375	1.75	2.00	1.50	2.006/2.002
650099538	1.75	2.00	2.00	2.006/2.002
650099539	1.75	2.00	2.25	2.006/2.002
6500995410	1.75	2.00	3.00	2.006/2.002
650099541	1.75	2.25	2.00	2.256/2.252
650099549	2.00	2.25	1.50	2.256/2.252
6500995495	2.00	2.25	2.00	2.256/2.252
650099550	2.00	2.25	2.50	2.256/2.252
6500995506	2.00	2.25	2.63	2.256/2.252
650099553	2.00	2.25	3.00	2.256/2.252
650099548	2.00	2.38	0.75	2.381/2.377
650099546	2.00	2.38	3.00	2.381/2.377
650099547	2.00	2.50	2.00	2.506/2.502
650099545	2.00	2.50	2.50	2.506/2.502
6500995571	2.50	2.75	2.75	2.756/2.752
6500995575	2.50	2.75	3.25	2.756/2.752
650099556	2.50	3.00	2.00	3.006/3.002
650099557	2.50	3.00	3.00	3.006/3.002
650099565	3.00	3.50	2.50	3.506/3.502

SPHERICAL BEARING

• Sometimes called self-aligning bearing
 • Unsealed

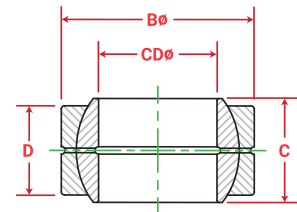

Part Number	CD +.0000" -.0005"	B	C	D	Housing Diameter
9995000050	0.500	0.875	0.435	0.375	0.8739 / 0.8747
9995000062	0.625	1.062	0.545	0.465	1.0614 / 1.0622
9995000075	0.750	1.250	0.655	0.562	1.2487 / 1.2497
9995000100	1.000	1.625	0.875	0.750	1.6237 / 1.6247
9995000125	1.250	2.000	1.093	0.937	1.9985 / 1.9997
9995000138	1.375	2.187	1.187	1.032	2.1860 / 2.1872
9995000150	1.500	2.437	1.312	1.125	2.4360 / 2.4372
9995000175	1.750	2.812	1.532	1.312	2.8110 / 2.8122
9995000200	2.000	3.187	1.750	1.500	3.1858 / 3.1871
9995000225	2.250	3.562	1.969	1.687	3.5607 / 3.5621
9995000250	2.500	3.937	2.187	1.875	3.9357 / 3.9371

NYLON INSERT LOCK NUT

- Grade 5
- Plain (no-finish)
- Also called non-metallic insert lock nuts or nylon nuts

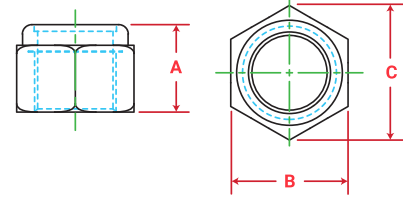

Part Number	Thread Size	A	B	C
4503816044	3/8"-16	0.44	0.55	0.63
4504414044	7/16"-14	0.44	0.62	0.69
4505020062	1/2"-20	0.56	0.75	0.81
4506218075	5/8"-18	0.75	0.93	1.06
4507516088	3/4"-16	0.88	1.06	1.19
4508814100	7/8"-14	1.00	1.25	1.38
4510014056	1"-14	0.56	1.43	1.65
4510014088	1"-14	0.88	1.62	1.81
4510014106	1"-14	1.06	1.44	1.62
4511212119	1-1/8"-12	1.19	1.62	1.81
4512512138	1-1/4"-12	1.38	1.81	2.06
4515012081	1-1/2"-12	0.81	2.19	2.51
4515012131	1-1/2"-12	1.31	2.38	2.62
4515012162	1-1/2"-12	1.62	2.19	2.44
4517512150	1-3/4"-12	1.50	2.75	3.06
4520012162	2"-12	1.62	3.12	3.50
4522512193	2-1/4"-12	1.93	3.50	3.93
4525012225	2-1/2"-12	2.25	4.00	4.38
4530012262	3"-12	2.62	4.49	4.96

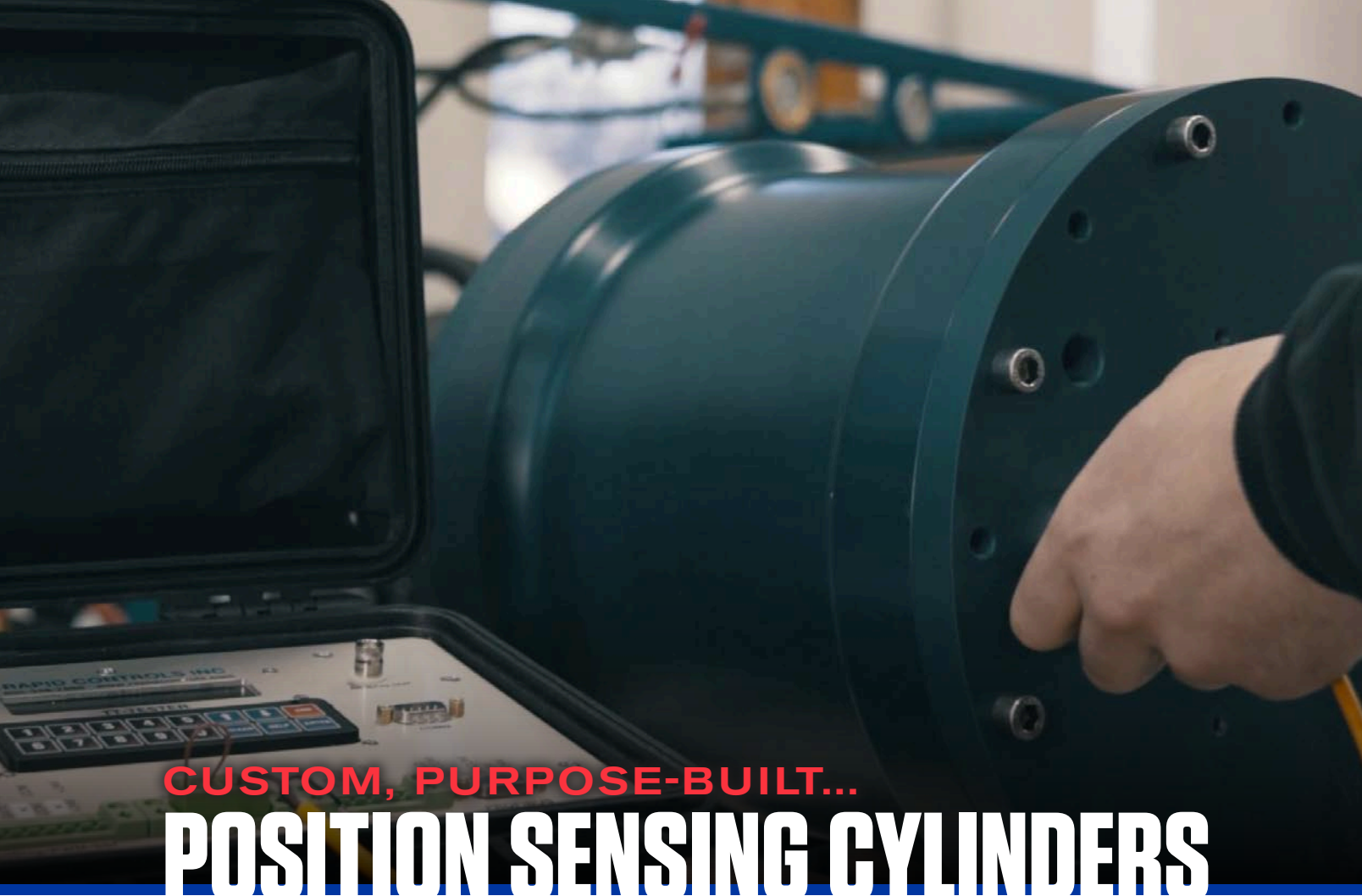

CUSTOM, PURPOSE-BUILT...

POSITION SENSING CYLINDERS

ADVANCED TECHNOLOGY INTEGRATION

When your machine is ready for all the benefits and reliability of electronic position feedback, it is time to integrate a linear transducer in your hydraulic cylinders.

We have a proven track record of designing and manufacturing smart cylinders for a wide variety of mobile and industrial applications.

**Equipment Users Today
Are Driven By Three Things:**

- Productivity
- Safety
- Return on Investment

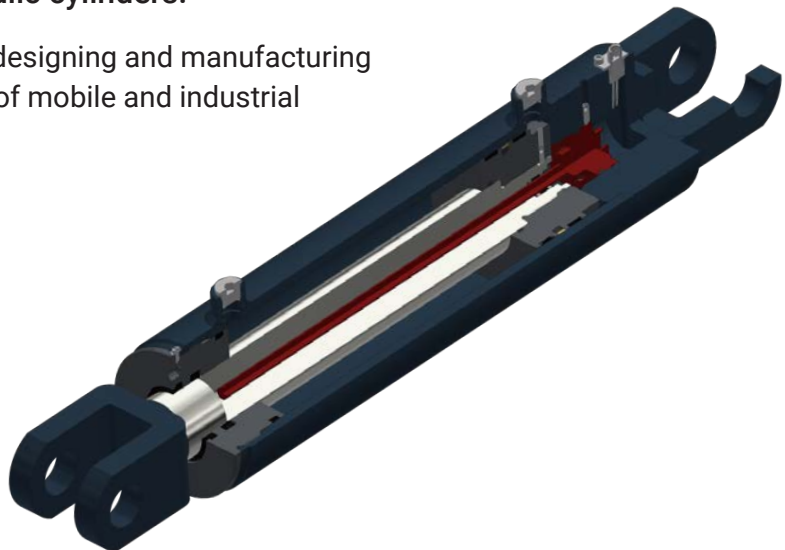



FACILITY TOUR

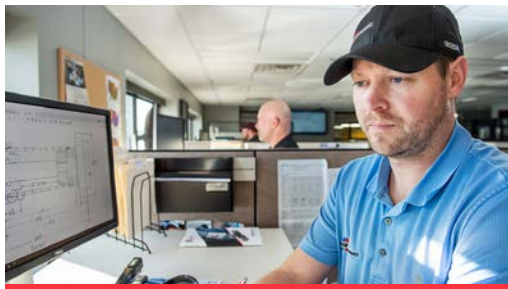

SALES

An experienced sales team is here and ready to help from initial inquiry to product delivery and beyond. We ask the right questions to understand your purpose-built application requirement.

- We ask the right questions
- We provide quick, accurate quotes
- We communicate order updates throughout

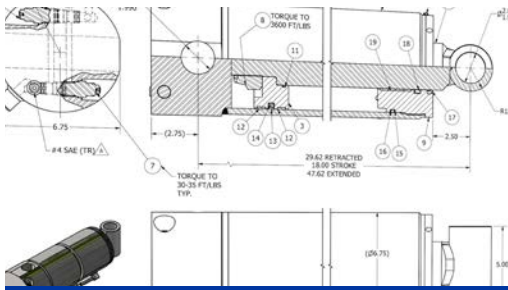

ENGINEERING

Our Engineering team at Aggressive Hydraulics works with sales to develop custom cylinder solutions based on your specific requirements. Our experts are here to be an extension of your business.

- Industry-leading turnaround on intricate drawings and models
- A proven design tracking process
- Experienced staff trained in the latest CAD tools
- Design standards and proprietary calculation tools



PRODUCTION CONTROL

Short lead times and on-time deliveries are vital. Our custom ERP system allows us to be responsive to your needs. That means maintaining short lead times with a high level of on-time delivery.

- Manufacturing processes that are defined, scheduled and tracked
- Real-time visual management of the production floor
- Accurate delivery times through job scheduling



RAW MATERIALS

We source the best materials from trusted suppliers. This standard ensures that you receive quality products every time. You know the type of product that you're getting when you order from Aggressive Hydraulics.

- Material certification validates raw material properties
- Serialized material tracking



MANUFACTURING

Quality is a critical part of everything we do. We diligently adhere to the highest quality standards and are in complete control of the manufacturing process. This allows us to provide you with products promptly.

- Flexible machining capabilities
- Welders—certified and robotic
- Continual investment in high-tech equipment



ENVIRONMENTALLY CONSCIOUS

At Aggressive Hydraulics, we take a proactive approach to reducing our environmental footprint. An environmentally conscious focus has extended beyond recycling oil, coolant, and metals.

- Air quality system within our facility
- Responsible disposal of consumables
- Wastewater filtration



ASSEMBLY & TESTING

Every single cylinder built at Aggressive Hydraulics is meticulously tested internally by our team. This attention to detail ensures that your cylinders meet our high standards and will immediately & safely deliver for you.

- Integrated electronic sensors are thoroughly tested with specialized equipment
- Automated fluid cleanliness and monitoring systems
- All cylinders are 100% tested



SHIPPING

The quality of Aggressive Hydraulics extends to shipping. Our shipping department handles all inbound and outbound shipments. Your products are always shipped with the same care and attention to detail that they received throughout the entire job cycle.

- Commitment to quality packaging
- Tracking information sent promptly
- Delivering product as it was when it left our shop

WEBSITE TOOLS

Providing innovative solutions beyond manufacturing cylinders

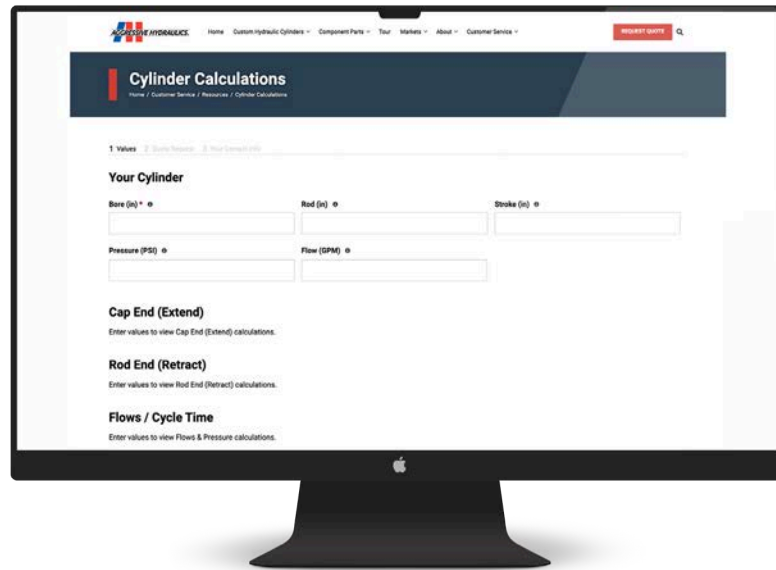

Aggressive Hydraulics has developed online tools to assist you in the quoting process. These comprehensive options streamline quoting—taking your RFQ to the next level.

These tools aid in the gathering of information for evaluation and pricing accuracy.

Go to our website and put these tools to work today.



Website Tools Include:

- Cylinder calculators
 - Rod cylinder
 - Single-acting telescopic
 - Double-acting telescopic
- Custom rod cylinder quoting app
- Pre-engineered cylinder drawing
- Rod cylinder quoting worksheet
- Telescopic cylinder quoting worksheet

TECHNICAL REFERENCE

Common Hydraulic Cylinder Formulas.

These formulas are helpful for those working with hydraulic cylinders. We also provide a Cylinder Calculator Tool on our website.

Extend Area (in²)	$\frac{\pi * \text{Bore Diameter (in)}^2}{4}$	Retract Rate (in/sec)	$\frac{\text{Flow (gpm)} * 231}{\text{Retract Area (in}^2) * 60}$
Extend Volume (in³)	$\frac{\pi * \text{Bore Diameter (in)}^2 * \text{Stroke (in)}}{4}$	Retract Force (lbs)	$\text{Retract Area (in}^2) * \text{Pressure (psi)}$
Extend Time (sec)	$\frac{\text{Extend Volume (in}^3) * 60}{\text{Flow (gpm)} * 231}$	Cylinder Ratio	$\frac{\text{Extend Area (in}^2)}{\text{Retract Area (in}^2)}$
Extend Rate (in/sec)	$\frac{\text{Flow (gpm)} * 231}{\text{Extend Area (in}^2) * 60}$	Flow out rod (gpm)	$\frac{\text{Flow in base (gpm)}}{\text{Cylinder Ratio}}$
Extend Force (lbs)	$\text{Extend Area (in}^2) * \text{Pressure (psi)}$	Flow out base (gpm)	$\text{Flow in rod (gpm)} * \text{Cylinder Ratio}$
Retract Area (in²)	$\frac{\pi * (\text{Bore Diameter (in)}^2 - \text{Rod Diameter (in)}^2)}{4}$	Cycle Time (sec)	$\text{Extend time (sec)} + \text{Retract Time (sec)}$
Retract Volume (in³)	$\frac{\pi * (\text{Bore Diameter (in)}^2 - \text{Rod Diameter (in)}^2) * \text{Stroke (in)}}{4}$	Hydraulic Power (HP)	$\frac{\text{Pressure (psi)} * \text{Flow (gpm)}}{1714}$
Retract Time (sec)	$\frac{\text{Retract Volume (in}^3) * 60}{\text{Flow (gpm)} * 231}$		



© **AGGRESSIVE HYDRAULICS**

18800 Ulysses Street NE, P.O. Box 187, Cedar, MN 55011

Phone: 763-792-4000 • Toll Free: 866-406-4100 • Fax: 763-792-4400

Email: Sales@AggressiveHydraulics.com • Web: www.AggressiveHydraulics.com

